



INSTALLER AND OWNER GUIDE

Model 963

Inset live fuel effect gas fire

Incorporating the Valor Fires **FireSlide**[®] Control.

Fitted with one of the following fascia:

Homeflame Dream, Petrus,
Masquerade or Excelsior.



(GC No. 32-032-92)

 **BUY NOW**

We trust that this guide gives sufficient details to enable this appliance to be installed, operated and maintained satisfactorily.

However, if further information is required, our

Valor Technical Helpline will be pleased to help.

Telephone **0844 879 35 88** (National call rates apply in the United Kingdom).

In the Republic of Ireland
Telephone **01 842 8222**.



INSTALLER: Please leave this guide with owner

THIS APPLIANCE IS FOR USE WITH NATURAL GAS (G20).

**UNDER NO CIRCUMSTANCES IS THIS FIRE TO BE CONVERTED TO LPG.
AN LPG KIT DOES NOT EXIST FOR THIS GAS FIRE.**

**THIS APPLIANCE IS SUITABLE ONLY FOR INSTALLATION IN THE UNITED
KINGDOM (GB) AND THE REPUBLIC OF IRELAND (IE).**

GDC Group Limited

All rights reserved. No part of this publication may be reproduced in any material form (including photocopying), stored in any medium by electronic means (including in any retrieval system or database) or transmitted, in any form or by any means, whether electronic, mechanical, recording or otherwise, without the prior written permission of the copyright owner.

Applications for the copyright owner's permission to reproduce any part of this publication should be made, giving details of the proposed use, to the following address: The Company Secretary, GDC Group Ltd., Millbrook House, Hedge End, Southampton, SO30 2DF.

Warning: Any person who does any unauthorised act in relation to a copyright work may be liable to criminal prosecution and civil claims for damages.



Valor Fires, GDC Group Ltd., Millbrook House, Hedge End, Southampton, SO30 2DF

Because our policy is one of constant development and improvement, details may vary slightly from those given in this publication

Safety First.

Valor Fires fires are CE Approved and designed to meet the appropriate British Standards and Safety Marks.



Quality and Excellence.

All Valor Fires fires are manufactured to the highest standards of quality and excellence and are manufactured under a BS EN ISO 9001 quality system accepted by the British Standards Institute.



The Highest Standards

Valor is a member of the Benchmark scheme and HHIC (Heating and Hot water Industry Council) that work to ensure high standards of safety, quality and performance.



Careful Installation

This gas fire must be installed by a competent GAS SAFE REGISTER operative in accordance with this installer guide.



INSTALLER GUIDE

FOR OWNER GUIDE SEE PAGES 47 TO 65

INSTALLER GUIDE

CONTENTS

<u>Section</u>	<u>Heading</u>	<u>Page</u>
	INSTALLER GUIDE	4 - 46
	OWNER GUIDE	47 - 65
1.	IMAGES	7
2.	SAFETY AND UNPACKING	8
3.	APPLIANCE DATA, EFFICIENCY AND NO_x	9
	3.1 General information.	9
	3.2 Efficiency.	10
	3.3 NO _x	10
	3.4 The Benchmarking Scheme	10
4.	GENERAL INSTALLATION REQUIREMENTS	11
	4.1 Regulations, Standards and Law.	11
	4.2 Ventilation requirements.	12
	4.3 The Atmosphere sensing device (ASD).	12
	4.4 Fireguard requirements.	12
	4.5 Room considerations.	12
	4.6 Chimney preparation.	12
	4.7 Fireplace preparation.	13
	4.8 The hearth and back panel.	13
	4.9 Fireplace clearances.	14
	4.10 Installation options.	16
	4.10.1 Conventional fireplace and hearth.	16
	4.10.1.1 'Hole-in-the-wall' Installations.	16
	4.10.2 Metal flue box and hearth.	17
	4.10.3 Precast concrete or clay flue block system and hearth.	18
	4.11 Flues.	19
5.	PACK CONTENTS	20
6.	FIREPLACE CHECK	23
7.	IGNITION CHECK	24
8.	GAS SUPPLY CONNECTION	25
9.	PREPARING APPLIANCE FOR INSTALLATION	25
	9.1 Appliance preparation.	25
	9.2 Fitting the foam seal.	26
	9.3 The flue restrictor.	27

Continued on next page

INSTALLER GUIDE

CONTENTS (Continued)

<u>Section</u>	<u>Heading</u>	<u>Page</u>
10.	CONVECTION BOX INSTALLATION	28
10.1	Method 1- Front fixing to fireplace surround.	28
10.2	Method 2 - Cable retention.	28
10.3	Floor sealing.	30
10.4	Sealing convection box holes.	30
11.	BURNER INSTALLATION	31
11.1	Burner and supply pipe installation.	31
11.2	Preliminary burner checks.	31
11.3	Inlet pressure check.	32
12.	FITTING THE CERAMIC FUEL EFFECT	32
13.	FITTING THE WINDOW	32
14.	SPILLAGE AND FLAME SUPERVISION CHECKS	33
15.	FITTING THE HEAT BAFFLE	35
16.	FITTING THE FASCIA	35
16.1	Dream/Masquerade/Excelsior and Petrus models.	35
16.2	Petrus model.	36
17.	FIREFRONT CASTING INSTALLATION	37
17.1	Fitting the Petrus rear screen assembly.	37
17.2	Fitting the Petrus fire front casting.	37
17.3	Fitting the Dream/Masquerade/Excelsior rear screen.	37
17.4	Fitting the Dream/Masquerade/Excelsior firefront casting.	37
18.	FULL OPERATING CHECKS	38
19.	FINAL REVIEW	39
20.	SERVICING & PARTS REPLACEMENT	40
20.1	Checking the aeration setting of the burner.	41
20.2	To remove the ignition microswitch.	41
20.3	To remove the gas shut-off microswitch.	41
20.4	To remove the fascia.	42
20.5	To remove the window.	42
20.6	To remove the burner unit.	42
20.7	To replace the control slide knob.	43
20.8	To remove the thermocouple interrupter block.	43
20.9	To remove the pilot unit.	44
20.10	To remove the shut-off tap.	44
20.11	To remove the gas flow rate controller.	45
20.12	To replace the burner.	45
20.13	To remove the main burner injector.	46
20.14	To remove the appliance from the fireplace.	46

INSTALLER GUIDE

1. IMAGES

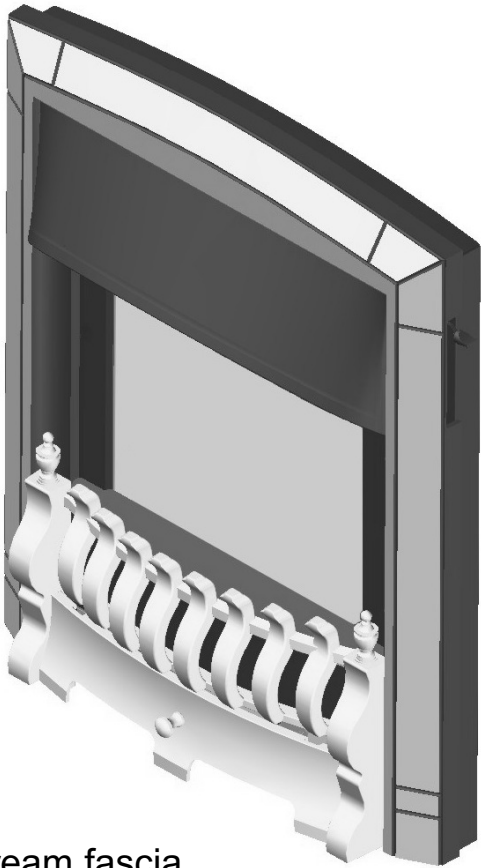

Dream fascia



Excelsior fascia

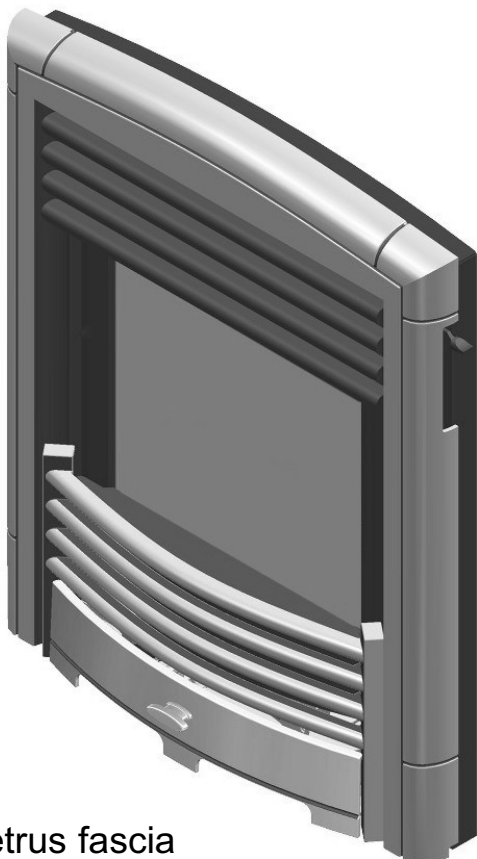

Petrus fascia

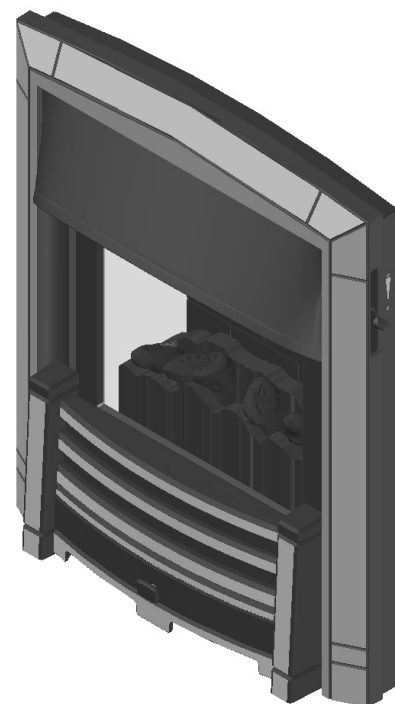

Masquerade fascia

INSTALLER GUIDE

2. SAFETY AND UNPACKING

Installer

Before continuing any further with the installation of this appliance please read the following guide to manual handling.

– The approximate lifting weight (kg) of this appliance is as below:

<u>Model</u>	<u>Heat Engine</u>	<u>Firefront</u>	<u>Combined Weight</u>
Dream	12	14	26
Petrus	12	12	24
Masq/Excel	12	12	24

- One person should be sufficient to lift the fire. If for any reason this weight is considered too heavy then obtain assistance.
- When lifting always keep your back straight. Bend your legs and not your back.
- Avoid twisting at the waist. It is better to reposition your feet.
- Avoid upper body/top heavy bending. Do not lean forward or sideways whilst handling the fire.
- Always grip with the palm of the hand. Do not use the tips of fingers for support.
- Always keep the fire as close to the body as possible. This will minimise the cantilever action.
- Use gloves to provide additional grip.
- Always use assistance if required.

This product uses fuel effect pieces and a burner compartment wall containing Refractory Ceramic Fibres (RCF), which are man-made vitreous silicate fibres. Excessive exposure to these materials may cause irritation to eyes, skin and respiratory tract. Consequently, it is important to take care when handling these articles to ensure that the release of dust is kept to a minimum. To ensure that the release of fibres from these RCF articles is kept to a minimum, during installation and servicing we recommend that you use a HEPA filtered vacuum to remove any dust and soot accumulated in and around the fire before and after working on the fire. When replacing these articles we recommend that the replaced items are not broken up, but are sealed within a heavy duty polythene bag, clearly labelled as RCF waste. RCF waste is classed as a stable, non-reactive hazardous waste and may be disposed at a landfill licensed to accept such waste. Protective clothing is not required when handling these articles, but we recommend you follow the normal hygiene rules of not smoking, eating or drinking in the work area and always wash your hands before eating or drinking. This appliance does not contain any component manufactured from asbestos or asbestos related products.

INSTALLER GUIDE

3. APPLIANCE DATA, EFFICIENCY AND NO_x

3.1 General information.

Gas	Natural (G20)
Inlet Pressure	20mbar
Input - Max. (Gross)	4.1kW (13,990 Btu/h)
Input - Min. (Gross)	2.3kW (7,848 Btu/h)
Input - Max. (Net)	3.69kW (12,590 Btu/h)
Input - Min. (Net)	2.07kW (7,062 Btu/h)
Inlet Test Pressure (Cold)	20.0 ± 1.0mbar (8.0 ± 0.4in w.g.)
Gas Connection	8mm pipe
Burner Injector	Cat 82 - 280
Pilot & Atmosphere Sensing Device	Copreci Ref. O.D.S 21100/234
Ignition	Electronic (Alkaline 9V PP3 Battery)
Aeration	See section 20.1

Under no circumstances is this fire to be converted to LPG. An LPG conversion kit does **not** exist for this gas fire.

The appliance information label is located on a 'swing out' plate at the base of the fire. On fires that are already installed this can be seen by removing the bottom front cover of the fascia.

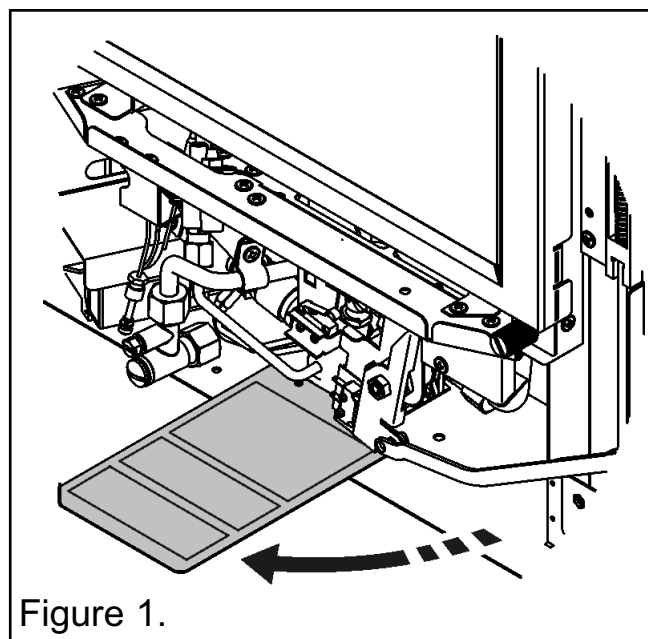

INSTALLER GUIDE

3.2 Efficiency.

The efficiency of this appliance has been measured as specified in BS 7977 - 1 and the result is as below:

<u>Model</u>	<u>Efficiency % (Gross)</u>	<u>Efficiency % (Net)</u>
963	72	80

The gross calorific value of the fuel has been used for this efficiency calculation. The test data from which it has been calculated has been certified by BSI (0086). The efficiency value may be used in the UK Government's Standard Assessment Procedure (SAP) for energy rating of dwellings.

The conversion of **net** efficiency to **gross** was achieved by multiplying the net efficiency by the following conversion factor from Table E3 of SAP 2005, rounding down to the nearest whole number.

Gas	Conversion factor from net to gross efficiency
Natural Gas	0.901

3.3 NO_x

The 'Weighted' result for this appliance equates to NO_x Class II.

3.4 The Benchmark Scheme

GDC Group is a licensed member of the Benchmark Scheme which aims to improve the standards of installation and commissioning of domestic heating and hot water systems in the UK and to encourage regular servicing to optimise safety, efficiency and performance. Benchmark is managed and promoted by the Heating and Hotwater Industry Council.

It places responsibilities on both manufacturers and installers. The purpose is to ensure that customers are provided with the correct equipment for their needs, that it is installed, commissioned and serviced in accordance with the manufacturer's instructions by competent persons and that it meets the requirements of the appropriate Building Regulations.

The Benchmark Checklist (on the inside back pages of this guide) can be used to demonstrate compliance with Building Regulations and should be provided to the customer for future reference.

Installers are required to carry out installation, commissioning and servicing work in accordance with the Benchmark Code of Practice which is available from the Heating and Hotwater Industry Council who manage and promote the Scheme.

Visit www.centralheating.co.uk for more information.

At the time of commissioning, complete all relevant sections of the Benchmark Checklist located on the inside back pages of this document.

4. GENERAL INSTALLATION REQUIREMENTS

4.1 Regulations, Standards and Law.

The installation must be in accordance with these instructions.

For the user's protection, in the United Kingdom it is the law that all gas appliances are installed by competent persons in accordance with the current edition of the Gas Safety (Installation and Use) Regulations. Failure to install the appliance correctly could lead to prosecution. GAS SAFE REGISTER and CORGI require their members to work to recognised standards.

In the United Kingdom the installation must also be in accordance with:

All the relevant parts of local regulations.

All relevant codes of practice.

The relevant parts of the current editions of the following British Standards:-

BS EN 1856 Part 1 -	Chimneys - Requirements for metal chimneys.
BS 715 -	Specification for metal flue boxes for gas-fired appliances not exceeding 20kW.
BS EN 1858 -	Chimneys - Components - Concrete flue blocks.
BS EN 1806 -	Chimneys - Clay / ceramic flue blocks.
BS 5440 Part 1 -	Installation of flues.
BS 5440 Part 2 -	Installation and maintenance of flues and ventilation for gas appliances of rated input not exceeding 70 kW net (1st, 2nd and 3rd family gases).
BS 6461 Part 1 -	Masonry chimney & flues - Installation
BS 1251 -	Fireplace components
BS 5871 Part 2 -	Installation - Inset LFE gas fires
BS 6891 -	Gas pipework installation

– In England and Wales, the current edition of the Building Regulations issued by the Department of the Environment and the Welsh Office.

– In Scotland, the current edition of the Building Standards (Scotland) Regulations issued by the Scottish Executive.

– In Northern Ireland, the current edition of the Building regulations (Northern Ireland) issued by the Department of the Environment for Northern Ireland.

– In the Republic of Ireland the installation must be carried out by a competent person and installed in accordance with:

a) The current edition of IS 813 "Domestic gas installations".

b) All relevant national and local rules in force.

c) The current building regulations

Where no specific instructions are given, reference should be made to the relevant British Standard Code of Practice.

INSTALLER GUIDE

4.2 Ventilation requirements.

Normal adventitious ventilation is usually sufficient to satisfy the ventilation requirements of this appliance. In GB reference should be made to BS 5871 Part 2 and in IE reference should be made to the current edition of IS 813 “Domestic Gas Installations” which makes clear the conditions that must be met to demonstrate that sufficient ventilation is available.

4.3 The Atmosphere sensing device (ASD).

The appliance is fitted with an A.S.D (Atmosphere sensing device). If the appliance closes down after a period of operation for no apparent reason, the consumer should be informed to stop using the appliance until the installation and appliance have been thoroughly checked. The A.S.D will shut the appliance down if an unacceptable amount of harmful products of combustion accumulate. Under no circumstances should the A.S.D be altered or bypassed in any way. Only a genuine manufacturer’s replacement part should be fitted. The individual A.S.D components are not replaceable.

4.4 Fireguard requirements.

A fireguard complying with BS 8423 should be fitted for the protection of young children, the elderly, the infirm and pet animals.

4.5 Room considerations.

4.5.1 This appliance must not be installed in any room that contains a bath or shower or where steam is regularly present.

4.5.2 An extractor fan may only be used in the same room as this appliance, or in any area from which ventilation for the appliance is taken, if it does not affect the safe performance of the appliance. Note the spillage test requirements detailed further on in this manual. If the fan is likely to affect the appliance, the appliance must not be installed unless the fan is permanently disconnected.

4.5.3 Note that soft wall coverings (e.g. embossed vinyl, etc.) are easily affected by heat. They may scorch or become discoloured when close to a heating appliance. Please bear this in mind when installing.

4.6 Chimney preparation.

4.6.1 If the appliance is intended to be installed to a chimney that was previously used for solid fuel, the flue must be swept clean prior to installation. All flues should be inspected for soundness and freedom from blockages.

4.6.2 Any chimney damper or restrictor should be removed. If removal is not possible, they must be secured in the open position.

INSTALLER GUIDE

4.7 Fireplace preparation.

4.7.1 If the fireplace opening is an underfloor draught type, it must be sealed to stop any draughts.

4.7.2 The fireplace floor should be reasonably flat to ensure that the convection box can be installed without it rocking and so that a good seal can be made at the bottom front of the box.

4.7.3 The front face of the fireplace should be reasonably flat over the area covered by the convection box top and side flange seals to ensure good sealing. These faces should be made good if necessary.

4.7.4 If the appliance is to be fitted against a wall with combustible cladding, the cladding must be removed from the area covered by the fascia. The cladding must also not touch the fascia (See figure 2). We suggest that the actual fascia is used as a template to mark the area for combustible cladding removal and that this area is increased by at least 2mm all round.

4.7.5 If the fireplace opening is greater than the acceptable dimensions given in this guide, do not use the back of a fire surround or marble to reduce the opening. This may cause cracking of the surround back or marble.

4.8 The hearth and back panel.

The appliance must be mounted behind a non-combustible hearth unless the conditions of section 4.10.1.1 are met (N.B. conglomerate marble hearths are considered as non-combustible). The appliance can be fitted to a purpose made proprietary class "O"-150°C surround. The hearth material must be at least 12mm thick. The periphery of the hearth (or fender) should be at least 50mm above floor level to discourage the placing of carpets or rugs over it. The appliance must not stand on combustible materials or carpets.

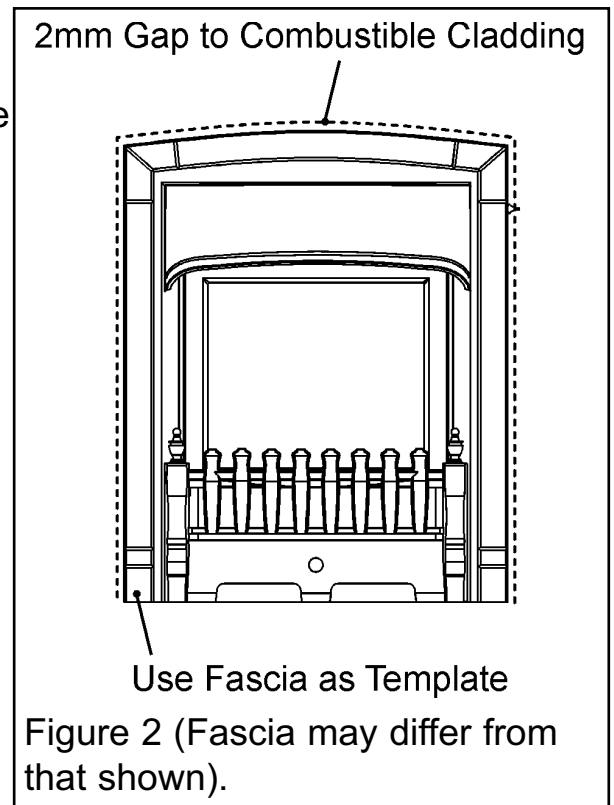

INSTALLER GUIDE

4.9 Fireplace clearances.

4.9.1 The minimum height from the base of the fireplace opening to the underside of any shelf made from wood or other combustible materials is detailed below.

For Homeflame Dream/Masquerade/Excelsior models -

- For a shelf up to 150mm deep: Minimum height = 700mm.
- For a shelf deeper than 150mm: 700mm + 12.5mm for every 25mm depth over 150mm (See Figure 3).

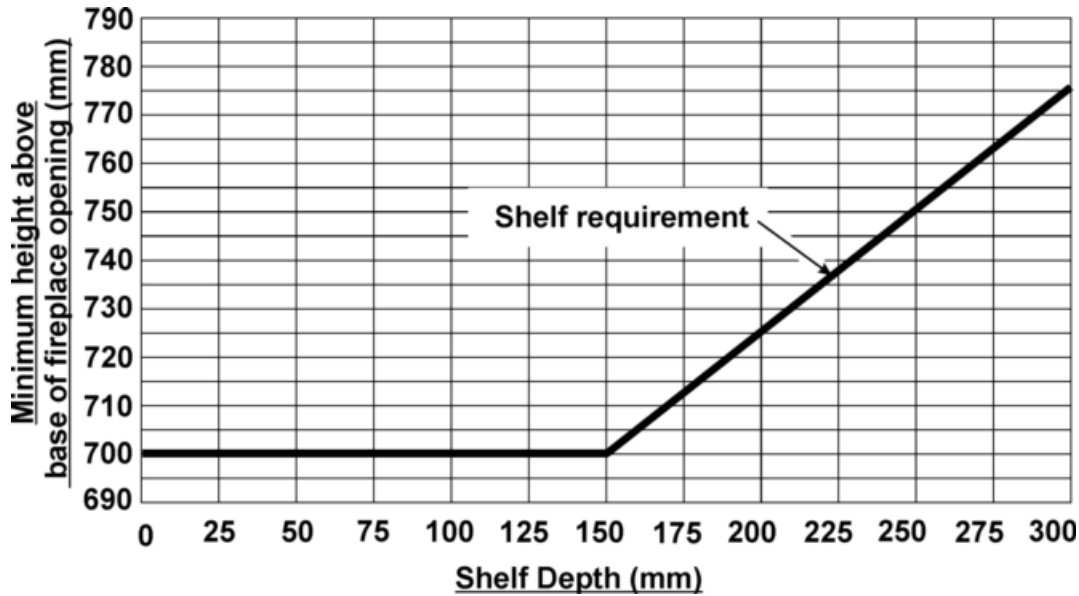

Figure 3. Combustible shelf clearances

For Homeflame Petrus model -

- For a shelf up to 150mm deep: Minimum height = 750mm.
- For a shelf deeper than 150mm: 750mm + 12.5mm for every 25mm depth over 150mm (See Figure 4).

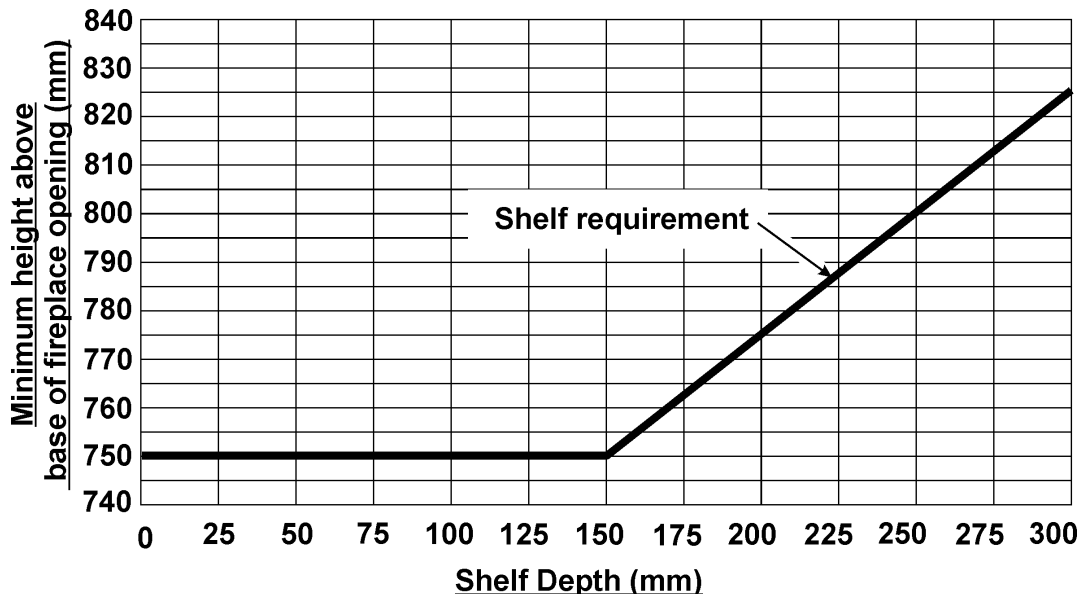
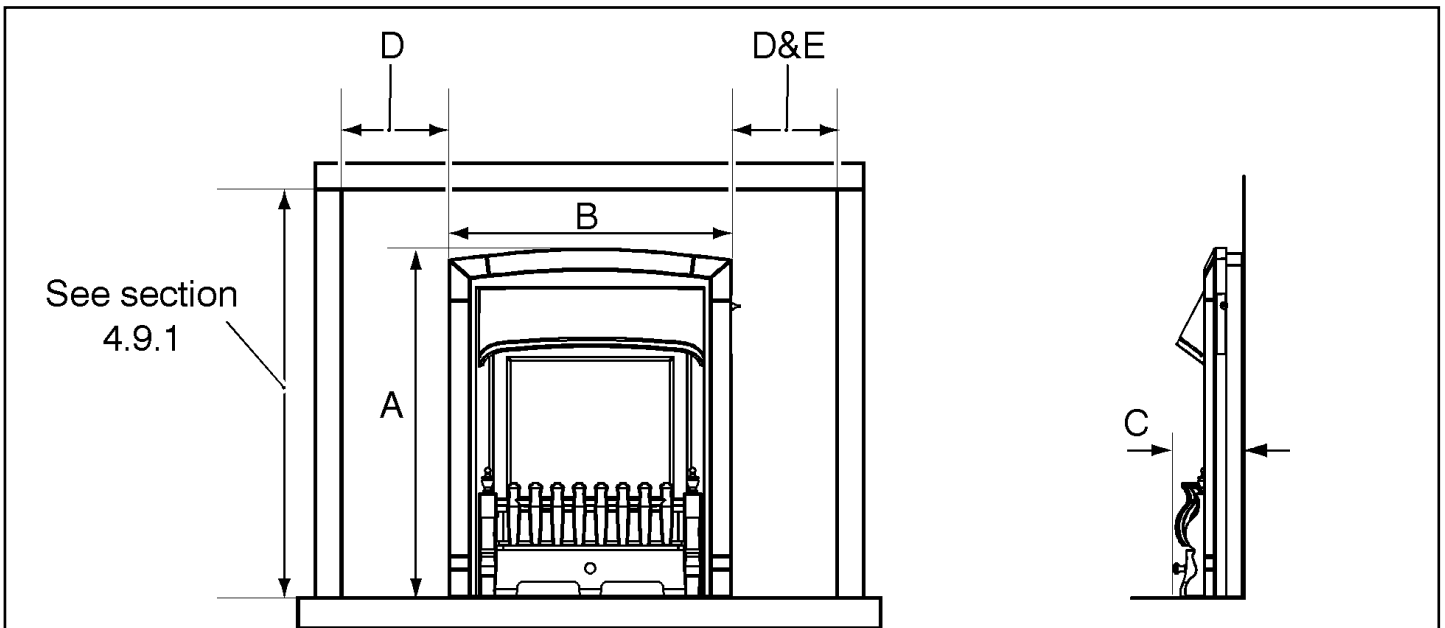

Figure 4. Combustible shelf clearances

INSTALLER GUIDE

4.9.2 The minimum allowable distance from the outside of the appliance fascia to a corner wall having combustible material or any other combustible surface which projects beyond the front of the appliance is shown in figure 5. A 10mm access clearance from a non-combustible surface is necessary at the left side.



Key	Description	Model	
		Dream/Masq/Excel	Petrus
A	Height (mm)	636	636
B	Width (mm)	518	518
C	Depth into room (mm)	142	94
D	Minimum mandatory clearance to combustible surfaces projecting beyond the front of appliance (mm).	100	100
E	Recommended clearance to non-combustible surfaces for access purposes (mm).	50	50

Figure 5. (The fascia may differ from that shown and dimensions are subject to manufacturing tolerances)

INSTALLER GUIDE

4.10 Installation options.

In the United Kingdom, as supplied, the appliance can be installed in the following situations: -

4.10.1 Conventional fireplace and hearth.

To a fireplace complete with hearth as shown in figure 6. Chair brick removal may not be required providing at least 50mm clearance is available from the flue outlet to any fireplace component.

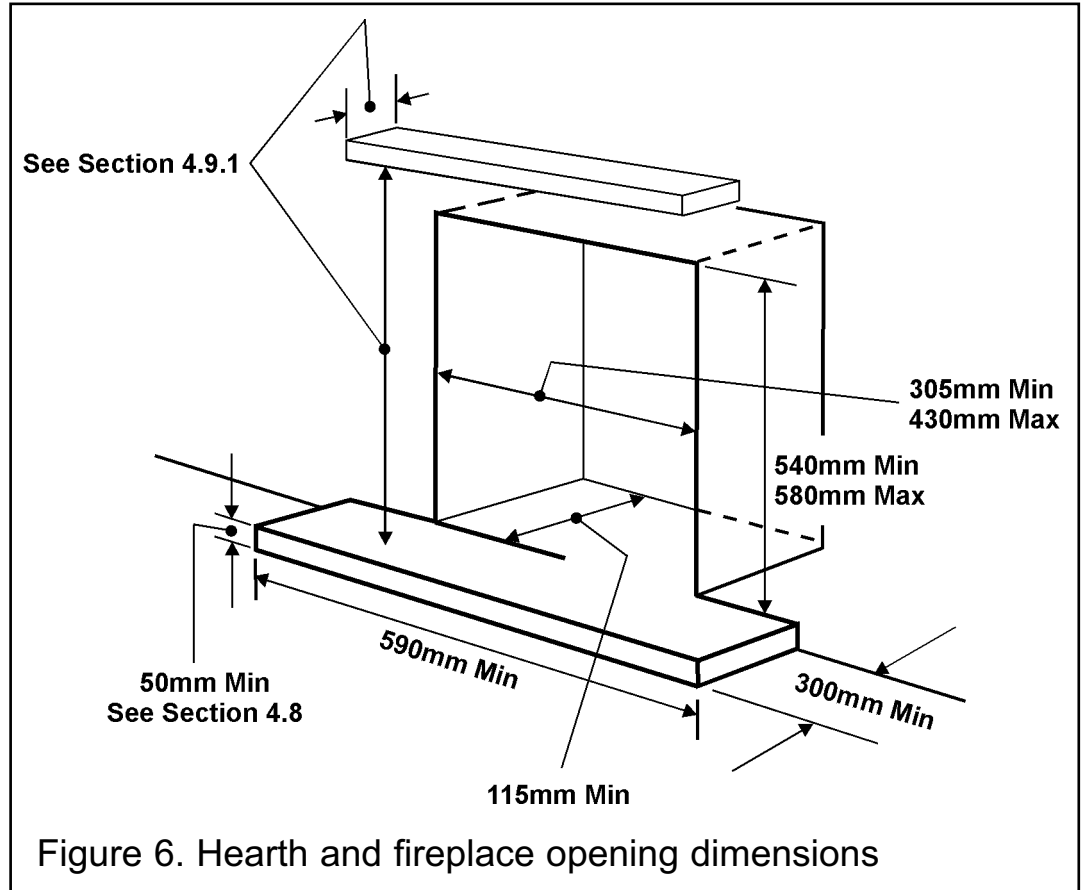

4.10.1.1 'Hole-in-the-wall' Installations.

- It is recommended that a hearth should be installed as in section 4.8 (See figure 6).
- If a reduced depth hearth is fitted, the fire must be installed so that the distance from the base of the fireplace opening in the wall to the finished floor level is at least 72mm. Where there is no floor covering or carpet and the floor is of a type that is likely to be covered in such a way then the distance from the base of the fireplace opening in the wall to the finished floor level should be increased to at least 147mm. If the lower part of the fascia (the firefront) is free standing, the recommended reduced hearth depth is 100mm. This is necessary to support the firefront (See figure 5 for appliance dimensions).
- To protect from the risk of burns and ignition of clothing a tactile separator shall be used. The hearth detailed in section 4.8 meets the requirements for a tactile separator. If this is not used then a 590mm long fender, kerb, horizontal bar, or other barrier, being fixed not less than 50mm above floor level and positioned 300mm in front of the fixing plane of the fire will meet the requirement.

INSTALLER GUIDE

4.10.2 Metal flue box and hearth.

The appliance can be installed to a fireplace incorporating a twin wall metal flue box complying with the constructional requirements of the current edition of BS 715 and with a flue conforming to BS EN 1856 part 1. The dimensions of the flue box must conform to those shown in figure 7.

The top surface of the metal flue box and the upper 200mm of the sides and rear faces must be covered with a 50mm layer of mineral wool or equivalent insulation (See figure 7).

Important Note: Where the flue box has a base sheet that is single wall (i.e. a single metal sheet) the flue box must be mounted on a non-combustible hearth. The hearth material must be at least 12mm thick.

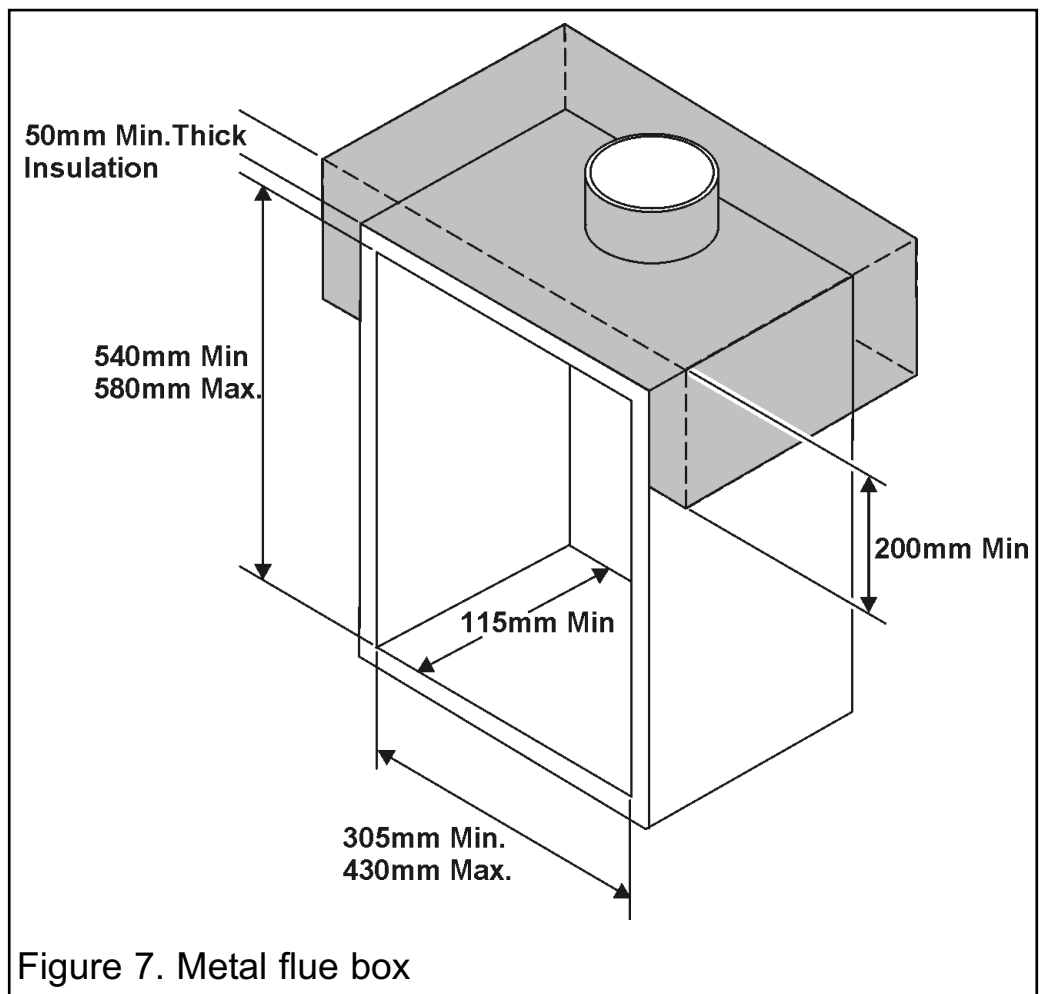

INSTALLER GUIDE

4.10.3 Precast concrete or clay flue block system and hearth.

The appliance can be installed to a precast concrete or clay flue block system conforming to BS1289 or BS EN 1858 with dimensions as in figure 8.

BS 1289 part 1 recommends there should be an air space or insulation between the flue blocks and the plaster because heat transfer may cause cracking on directly plastered flues. However, generally this appliance is suitable for installations under all circumstances unless there is a history of cracking problems. Remember that faults such as cracking may be caused by poorly built and restrictive flues, e.g. mortar extrusions, too many bends, flue heights below three metres, restrictive terminations etc.

The appliance is suitable for installations conforming to older versions of BS1289 as well as the current edition. The flue blocks must have a minimum width (Depth as you look at the flue block when installed) not less than 63mm and a cross-sectional area not less than $13,000\text{mm}^2$. Older editions of BS1289 required a cross-sectional area of $13,000\text{mm}^2$. The current revision of the standard requires $16,500\text{mm}^2$. This appliance is suitable in both cases. The total depth of the opening measured from the finished front of the fireplace (Including plaster, surround etc.) must be 115mm.

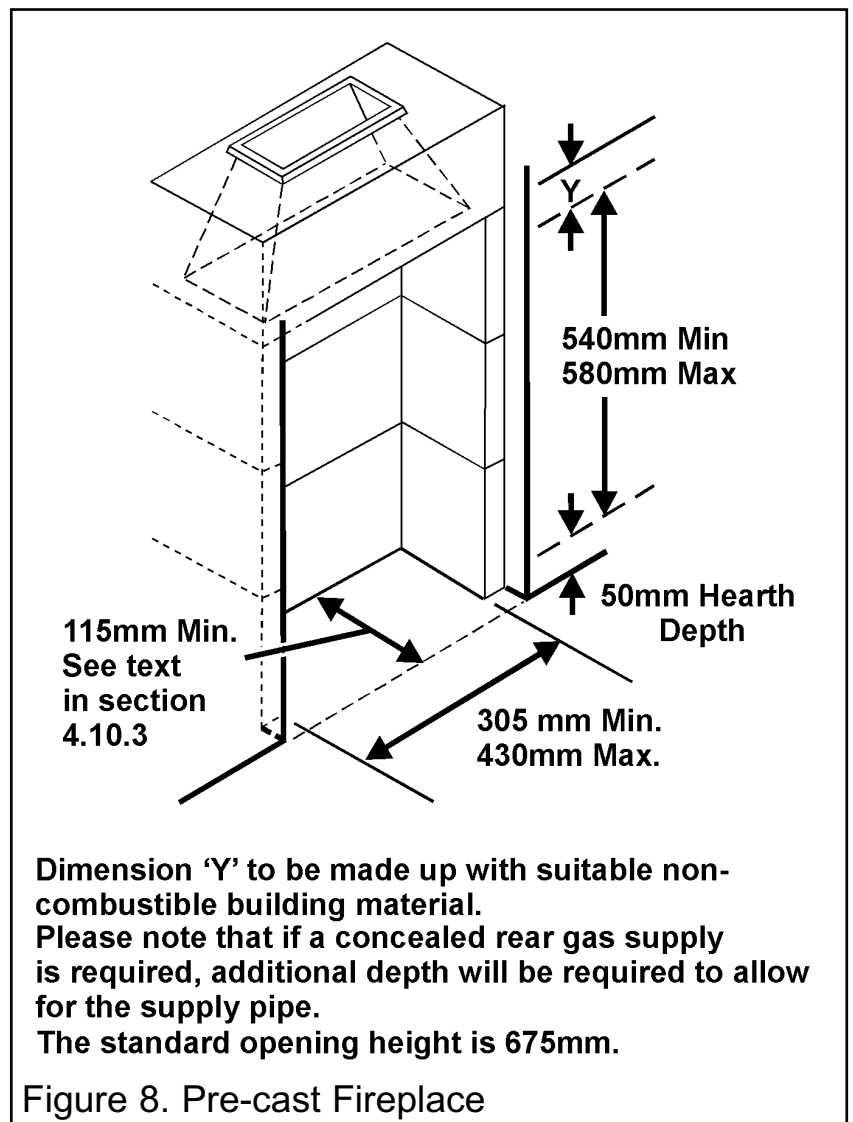

INSTALLER GUIDE

4.11 Flues.

1. Suitable flues and minimum flue sizes are as follows:

It should be noted that, as with many appliances, sharp bends or horizontal runs in metal flues at the top of the system can be a cause of problems in these types of installation.

- 225mm x 225mm conventional brick flue.
- Single wall, twin wall or flexible flue liner with a minimum diameter of 125mm. The materials to be used are stainless steel or aluminium as specified in BS EN 1856 Part 1. The liner must be sealed to the surrounding area above the fireplace opening and to the top of the chimney. An approved terminal must be fitted.
- 175mm diameter lined brick or stone flue.
- 200mm diameter factory made insulated flue manufactured to BS4543 Part 2.
- 175mm diameter flue pipe. See BS6461 Part 1 for suitable materials.
- A properly constructed precast concrete or clay flue system conforming to BS1289 or BS EN 1858. This system is only suitable if the conditions stated in section 4.10.3 are met.

2. The flue must conform to BS 5440: Part 1 in design and installation.

The flue, measured from the bottom of the fireplace opening to the bottom of the terminal, shall be not less than 3m in actual vertical height. When calculated in accordance with BS 5440: Part 1 Annex A, the minimum **equivalent** height of the flue shall be 2.0m of 125mm dia. flue pipe.

3. The flue must not be used for any other appliance or application.

4. Proprietary terminals must comply with BS 715 or BS 1289. Any terminal or termination must be positioned in accordance with BS 5440 Part 1 to ensure that the products of combustion can be safely dispersed into the outside atmosphere. Where the appliance is connected to an unlined brick chimney it is generally unnecessary for the chimney pot to be replaced or for a terminal to be fitted unless the flue has a diameter smaller than 170mm.

5. The flue must be completely sealed so that combustion products do not come into contact with combustible materials outside the chimney.

INSTALLER GUIDE

5. PACK CONTENTS

The items required for this appliance are packed in sections.

Pack 1 - Fire unit contains:

- 1 Heat engine.
- 1 Hood (Dream/Masq/Excel models only).
- 1 Louvre assembly (Petrus model only).

- 1 Loose parts pack including: -
 - 1 Grommet for rear of convection box.
 - 2 Strips of floor sealing tape.
 - 6 Fibre / wooden plugs.
 - 4 Wood screws.
 - 2 Fire retaining cables.
 - 2 Cable adjusters.
 - 4 Eyebolts.
 - 1 Length of self-adhesive foam seal.
 - 1 Inlet "T" connector including pressure test point, nut and olive for 8mm inlet pipe.
 - 1 Alkaline 9V PP3 battery.
 - 1 Ceramic fuel effect pack (Not shown).
 - 3 No.8 x 3/8 screws (Black) for securing the outlet baffle.
 - 4 No.8 x 3/8 screws (Black) for securing the Dream hood.
 - 4 M4 x 25 screws for securing the fascia.
 - 2 Washers for securing the fascia.
 - 1 Smoke match tube.
 - 1 Outlet baffle
 - 1 Control knob
 - 2 M4 x 7mm screws for securing the control knob.

Pack 2 - Petrus Fire front contains

- 1 Fascia
- 1 Firefront casting
- 1 Front cover casting.
- 1 Rear screen assembly.
- 2 Screws

Pack 2 - Dream/Masq/Excel Fire front contains

- 1 Fascia
- 1 Firefront casting
- 1 Front cover casting.
- 1 Rear upper screen.
- 2 Screws

Remove all the items carefully to prevent damage. Take special care when handling the ceramic components. Some items may be contained in the packaging fittings - Examine the packaging carefully before discarding. Check that all the items are present and undamaged.

INSTALLER GUIDE

Petrus outlet baffle (1 off)

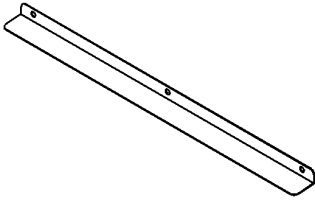

Dream/Masq/Excel Outlet baffle (1 off)

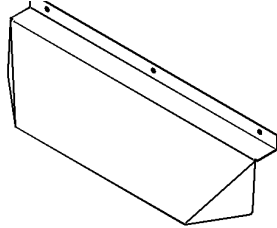

Control knob

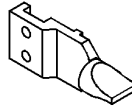

Heat engine (1 off)

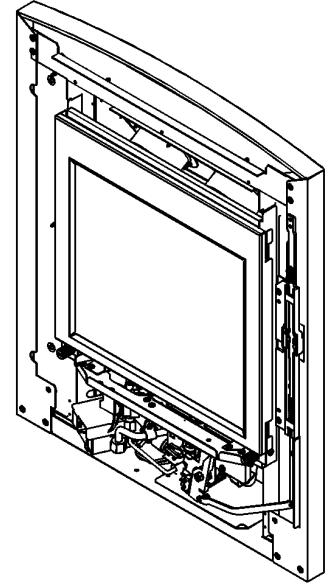

3 off No.8 x 3/8" Black Pozi
For securing outlet baffle.

4 off No.8 x 3/8" Black Pozi
For securing Hood on Dream.

M4 x 7mm screw (2 off)
For securing control knob



Wood screws (4 off)

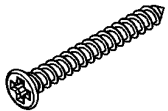

Fibre / Wooden Plugs (6 off)

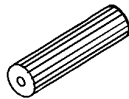

Washer (2 off)

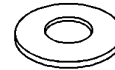

Rubber grommet (1 off)

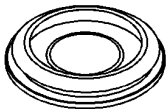

Alkaline Battery (1 off)

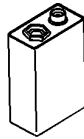

M4 x 25mm screw (2 off)



Eyebolt (4 off)

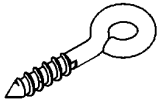

Self-Adhesive Foam Strip (1 off)



Fire Retaining Cable (2 off)



Nut and olive (1 off)

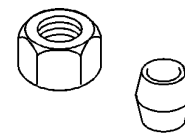

Cable Adjuster (2 off)

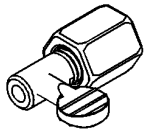

Floor sealing tape (2 off)

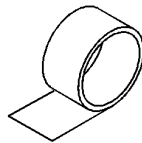

Inlet 'T' connector (1 off)

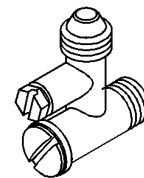

Dream/Masq/Excel hood (1 off)

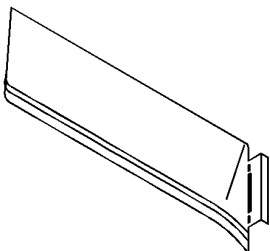

Petrus louvre (1 off)

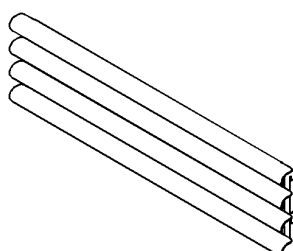

Smoke match tube (1 off)

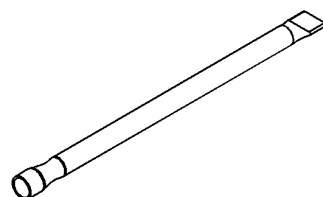
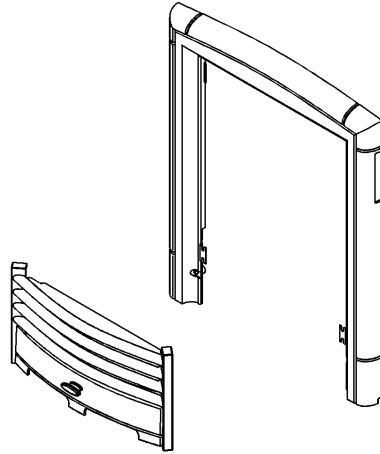

Figure 9. Pack one contents (Continued on next page)

INSTALLER GUIDE

Petrus fascia



Dream fascia

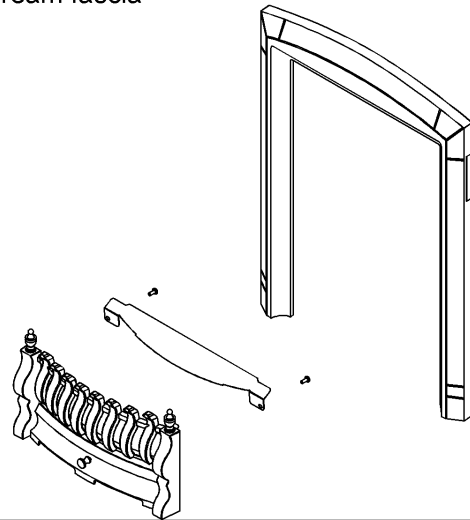

Masquerade & Excelsior fascia
(Masq Fret shown here)

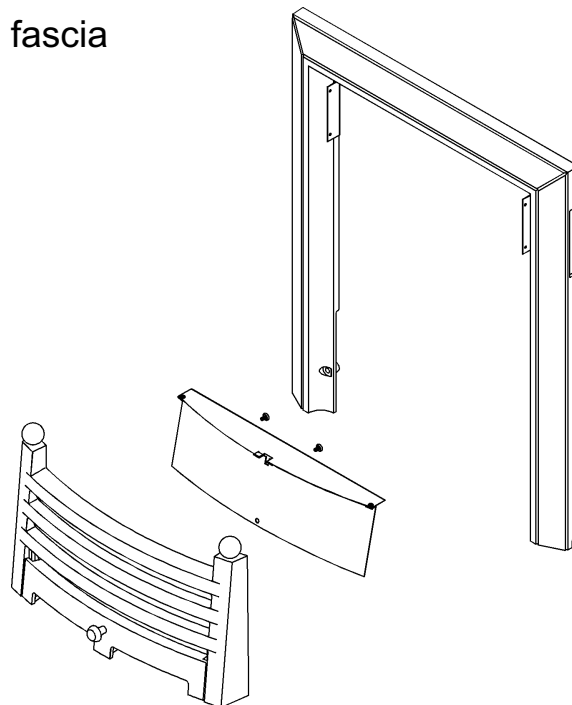

Figure 9. Pack two contents

INSTALLER GUIDE

6. FIREPLACE CHECK

6.1 Soundness for appliance attachment.

Two primary methods of retaining the appliance are provided: -

- 1) By fixing to the fireplace front surround.
- 2) Using concealed fire retaining cables fixed to the rear of the fireplace opening together with secondary fixing to the fireplace floor.

The methods are detailed in section 10 of this guide. Before selecting the retention method, consult with the customer. Method 2 is provided for instances where drilling holes in the front surface of the fireplace surround is unacceptable to the customer or otherwise impractical. *N.B. It is unwise to attempt to drill into marble without the proper tools and equipment.*

If method 1 is chosen, make sure that the front surround area is sound enough to take the fibre / wooden plugs and wood screws. If necessary, make sound with suitable cement.

If method 2 is chosen, make sure that the areas at the back and base are sound enough to take the eyebolts and wood screws. If these areas have deteriorated due to prolonged use, they should be made sound with suitable cement.

6.2 Fireplace flue pull.

Close all doors and windows in the room in which the appliance is to be installed. After confirming with a match that smoke is drawn into the flue, light a 13 gram smoke pellet and check that there is a definite flow through the flue. Verify outside that the smoke exits from one terminal only and that the termination is suitable. Observe where possible, upstairs rooms and loft spaces for signs of escaping smoke indicating a defective flue. If there is not a definite flow, warm the flue for a few minutes and repeat the smoke pellet test. If there is still no definite flow the flue may need remedial work – **Do not fit the appliance until there is a definite flow through the flue.**

NOTE: This appliance has an integral adjustable flue draught restrictor. This is supplied in the fully open position. This restrictor should be adjusted to the fully closed position if the flue height is greater than 4.3m (14ft), with a good draught present.

Generally we recommend the flue restrictor is not fitted to precast flues or metal flue box installations. There may be circumstances where fitting the restrictor to the fully closed position causes the fire to fail the spillage test, in such cases the restrictor will have to be adjusted to a more open position. After adjustment conduct the spillage test again and repeat if necessary until a good pass is achieved.

INSTALLER GUIDE

7. IGNITION CHECK

Before attempting to install, it is worth checking that the electronic ignition system performs satisfactorily.

- Fit the control knob to the slider assembly using two M4 x 7mm screws supplied (See figure 10)
- Fit the battery to the ignition block located below the burner tray at the left side (See figure 11). The +ve and -ve terminal positions are marked on the battery holder body.
- Depress the slider control knob as far as it will go. This should close the ignition circuit. Sparks should be seen tracking from the electrode pin to the pilot tip (See figure 12).
- If there are no sparks make the following checks.
- Check condition of battery and that it is correctly located.
- If the above is satisfactory, check the ignition circuit and components - see the servicing and parts replacement section in this guide.

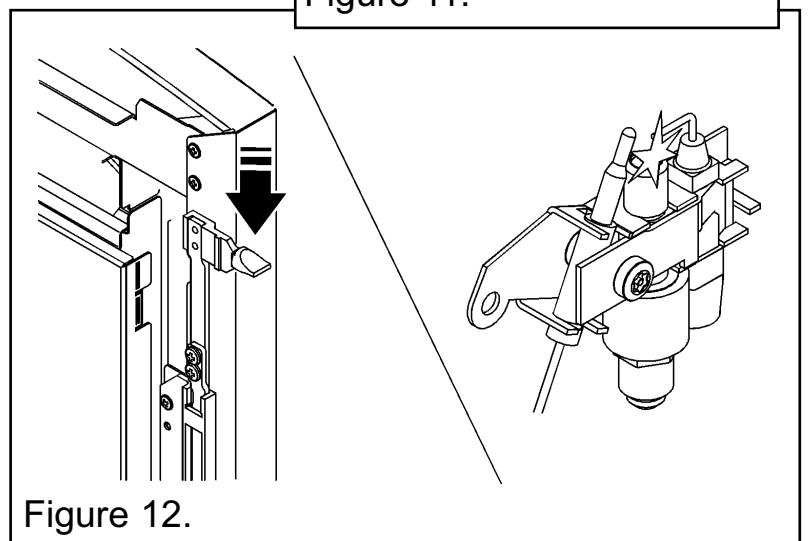
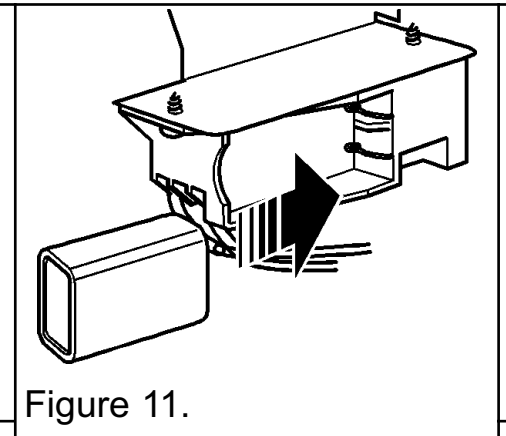
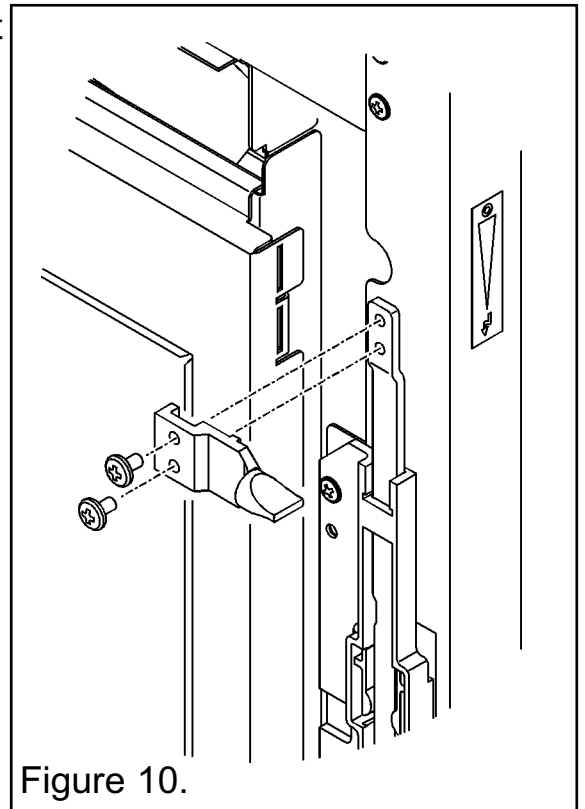

INSTALLER GUIDE

8. GAS SUPPLY CONNECTION

A nut and olive are provided for an 8mm pipe inlet connection to the inlet 'T' connector at the bottom front of the appliance. The inlet 'T' connector can be rotated to allow a connection from any direction. The inlet 'T' connector includes a valve for isolating the gas supply and a pressure test point.

The supply pipe must be rigid material. Flexible pipe must not be used.

Concealed supply pipe connection.

If a concealed connection from inside the fireplace is required then, **before the appliance is fitted into the fireplace** it will be necessary to extend the supply line so that it will project through the hole in the back of the convection box and run to the inlet 'T' connector at the front. The pipe run from the supply line up to the rear opening in the convection box must be kept away from the area which will be taken by the convection box when it is installed. Note that the centre of the appliance inlet 'T' connector is 25mm above the fireplace floor. The inlet 'T' connector should be fitted to the supply pipe at this stage.

9. PREPARING APPLIANCE FOR INSTALLATION

9.1 Appliance preparation.

1. Remove any transit tape and packing and inspect for any evidence of mishandling which might affect the performance of the fire.

2. Detach and remove the window assembly. To do this unscrew and remove the two thumbscrews at the base of the window assembly. Gently lift the window assembly upward and forward (See figure 13). Place the window assembly and thumbscrews in a safe place away from the work area.

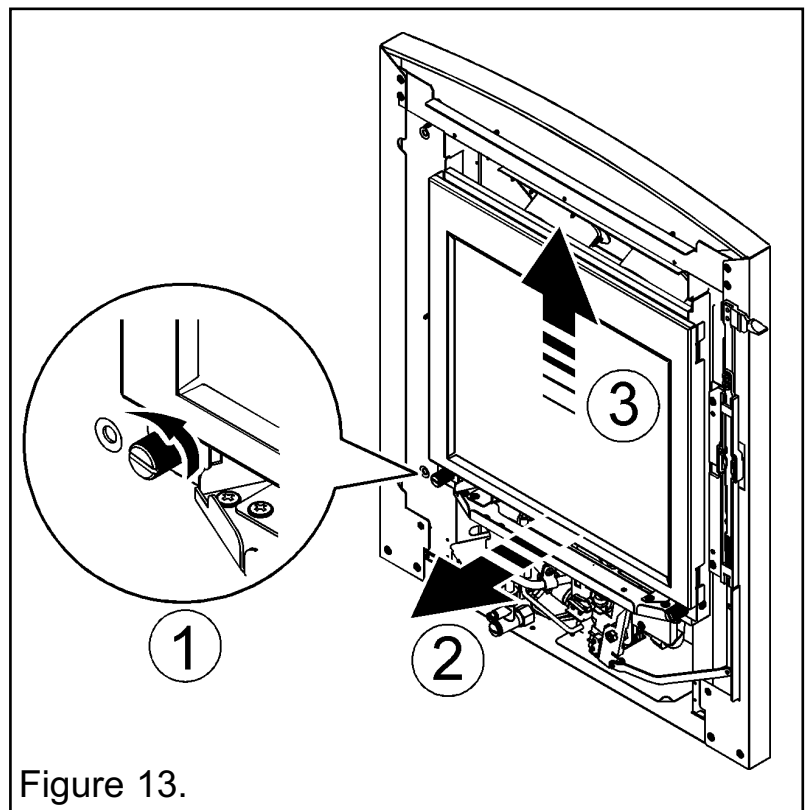

Figure 13.

INSTALLER GUIDE

3. Unscrew and remove the screw that secures the slider arm assembly to the burner (See figure 14).

4. Each unit is flame tested before it leaves the factory and as a result there may be slight discolouration around the burner ports. Detach the burner unit from the convection box by removing two screws (See figure 15). Lift the burner unit clear.

5. It is important that the grommet supplied in the loose parts pack is fitted to the hole in the rear of the convection box (See figure 16).

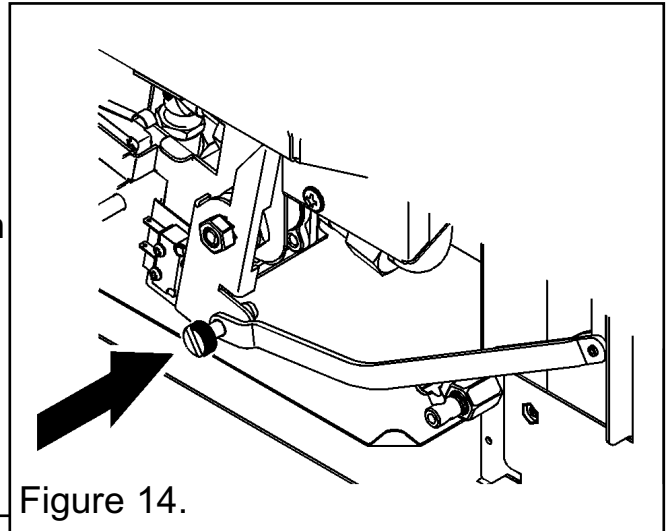

Figure 14.

9.2 Fitting the foam seal.

There is a length of self adhesive foam seal supplied with the fire. This will need to be fitted to the rear of the convection box as shown in figure 16. Cut the foam seal to the required lengths. Be careful not to stretch the seal when measuring. Remove the protective backing from the foam seal and fit this to the rear of the convection box flange (See figure 16).

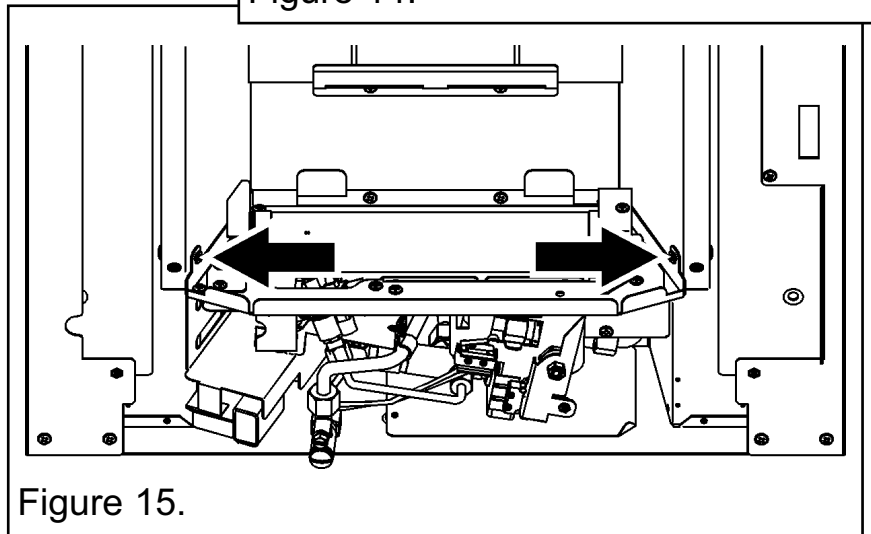

Figure 15.

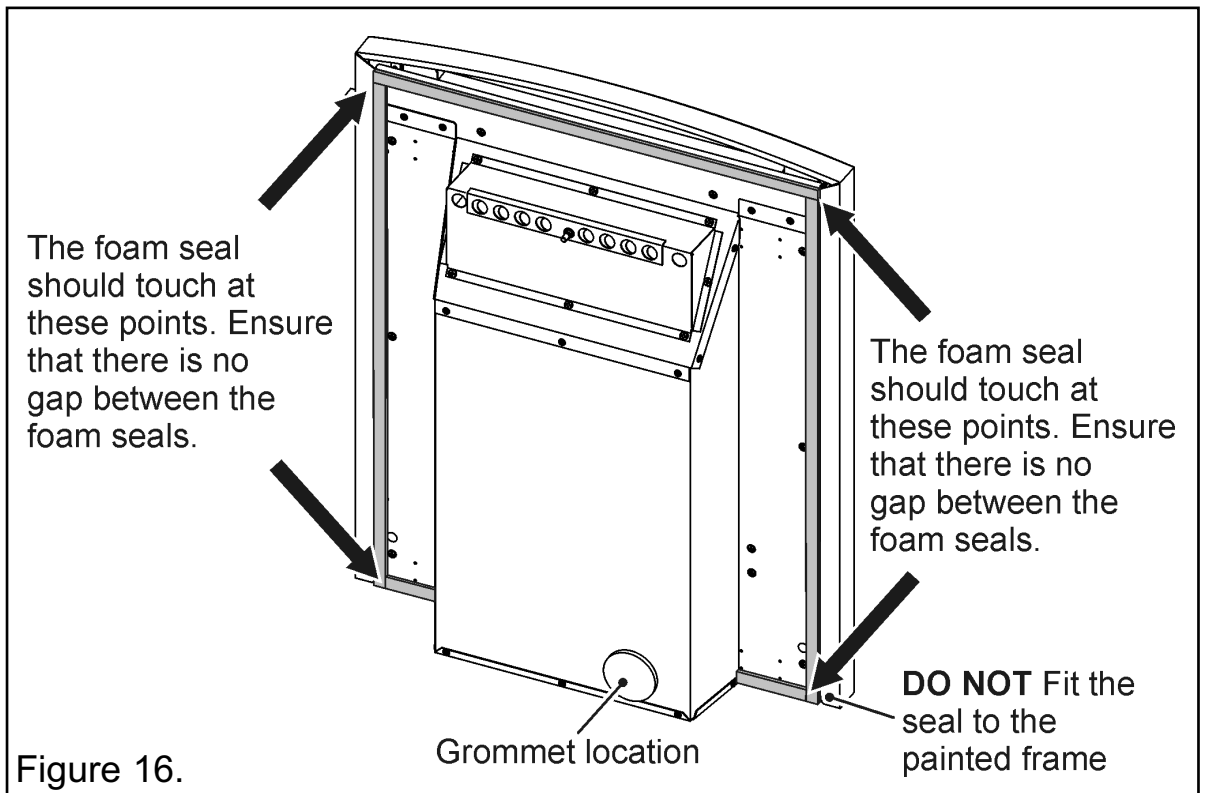

Figure 16.

INSTALLER GUIDE

9.3 The flue restrictor.

This appliance is fitted with a flue restrictor for use where the flue draught is excessive. The flue restrictor can be adjusted from the front of the fire so there is no need to remove the fire from the fireplace for adjustment to be made. Generally we recommend the restrictor is set to its fully open position where a precast flue, metal flue box or a flue liner is used, however, certain flues may work sufficiently to warrant its use. There may however, be circumstances where the restrictor causes the fire to fail the spillage test. In such cases the restrictor will have to be set to its fully open position and a spillage check conducted again.

The restrictor is supplied in the fully open position and can be adjusted. To adjust the restrictor, locate the central screw at the rear of the convected air outlet (See figure 17). Loosen the screw and with the screw driver still in the head of the screw, slide the restrictor to the desired position. Secure the restrictor by tightening the screw.

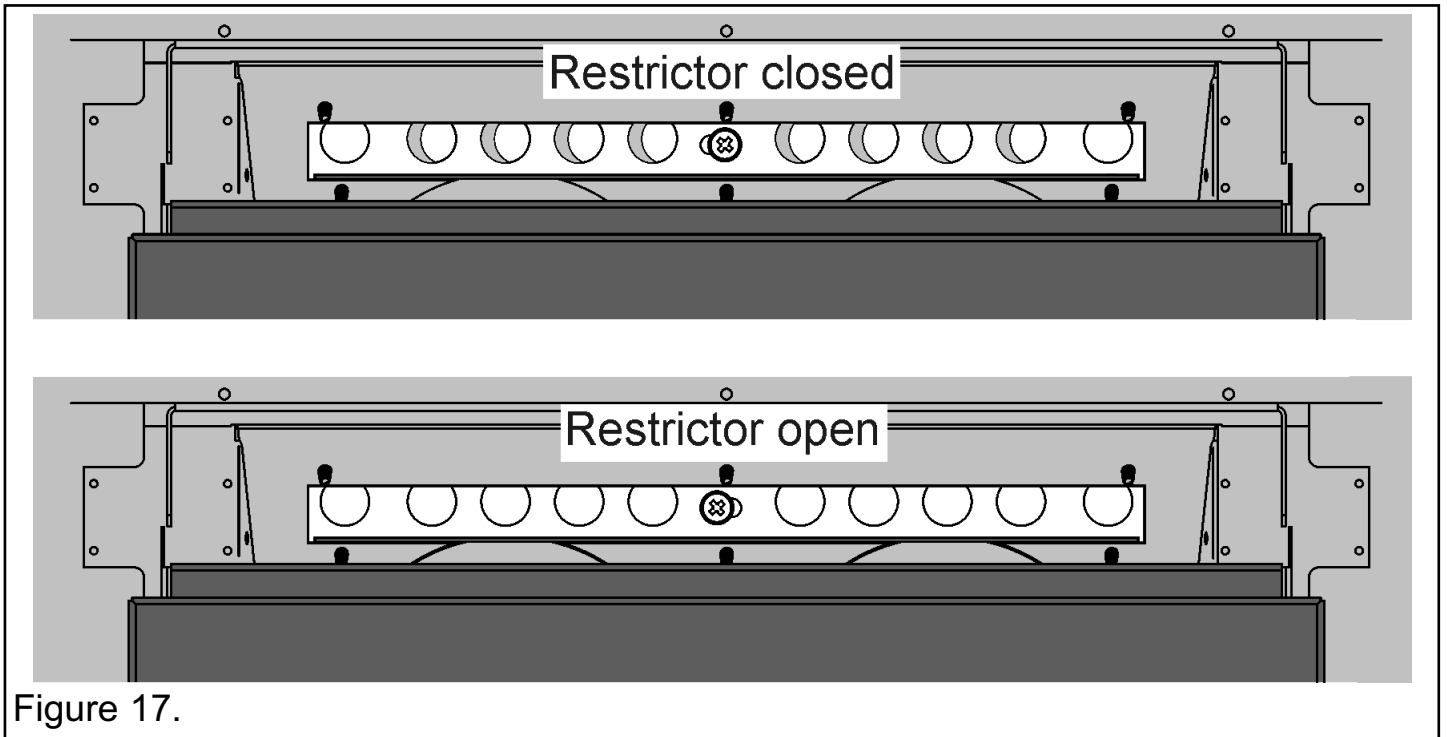

INSTALLER GUIDE

10. CONVECTION BOX INSTALLATION

10.1 Method 1- Front fixing to fireplace surround.

1. Make sure that the fireplace front surround area is sound enough to take the fibre / wooden plugs and wood screws. If necessary, make sound with suitable cement.

2. Place the convection box centrally in the fireplace in the position in which it is to be permanently installed. If a concealed connection is being used, insert the convection box into the fireplace feeding the supply pipe through the pierced hole in the grommet.

3. Mark the fireplace front surround through the four fixing holes in the side flanges of the convection box (See figure 18).

4. Remove the convection box. Drill four holes in the fireplace front surround at the marked positions using a suitably sized masonry drill for the fibre / wooden plugs supplied.

5. Insert a fibre / wooden plug into each hole.

6. Place the convection box back in position in the fireplace.

7. Fit a wood screw through each hole in the convection box flanges and tighten to seal the box to the fireplace surround.

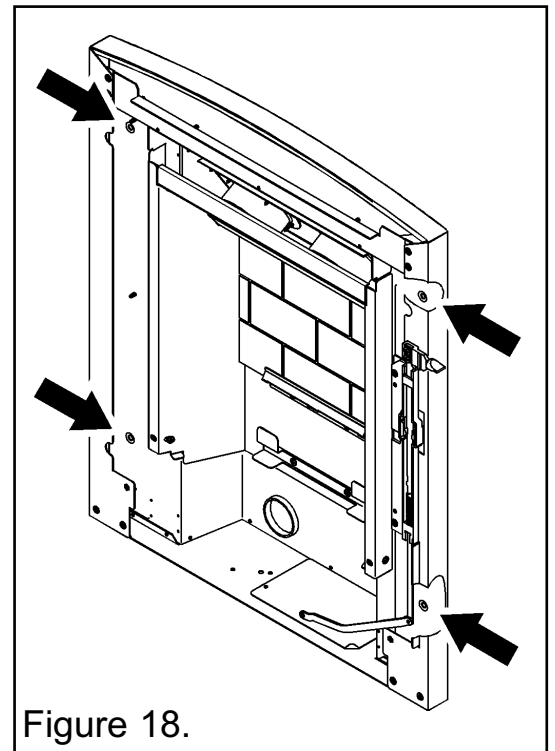

Figure 18.

10.2 Method 2 - Cable retention.

1. Make sure that the relevant areas at the fireplace back and floor are sound enough to take the eyebolts and screws. If these areas have deteriorated due to prolonged use they should be made sound with suitable cement.

2. Drill four holes in the rear wall of the fireplace for the eyebolt plugs. The holes should be drilled within the range of positions shown in figure 19 using a suitably sized masonry drill for the fibre / wooden plugs supplied. The holes should be equidistant each side of the centre line of the

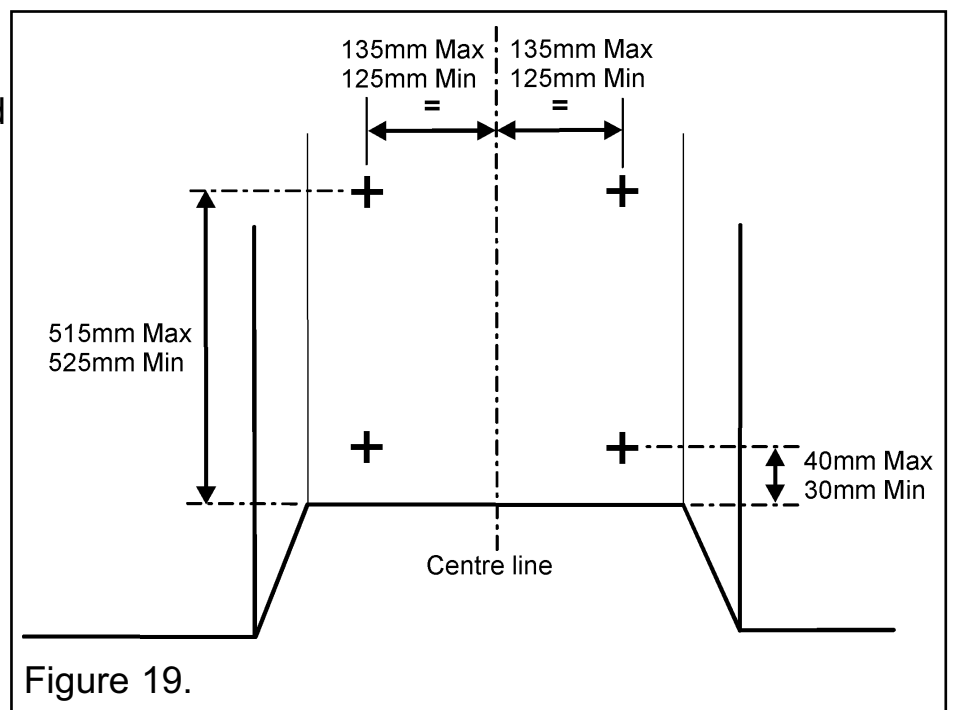

Figure 19.

INSTALLER GUIDE

fireplace to ensure that the appliance finishes centrally in the opening when tension is applied to the cables.

3. Insert a fibre / wooden plug into each hole. Use the fibre / wooden plugs supplied with this appliance - **Never use plastic plugs instead of the fibre / wooden plugs supplied.** Screw the eyebolts into the plugs. Make sure that the bolts are secure.

4. Place the convection box unit close to the fireplace but allow sufficient access into the fireplace opening so that the cables can be threaded through the eyebolts and returned through the convection box. If a concealed connection is being used, insert the convection box into the fireplace feeding the supply pipe through the pierced hole in the rear seal.

5. The fire has eight pairs of small holes for cable securing, only four will be used. For openings up to 382mm wide use the inner set of holes. For openings above this use the outer holes (See figure 20). Once the upper pairs of holes are selected, feed approximately 100mm of cable from the rear of the fire through the upper hole, then feed approximately 20mm of cable into the lower hole. Gently pull the upper cable from the rear of the fire to lock into place (See figure 21). Repeat this on both sides.

6. Thread the cables through the eyebolts in the rear wall. Return the cables through the selected hole near the bottom of the convection box (See figure 21).

7. Ensuring it is aligned correctly and central, place the convection box fully back into the fireplace opening so that it is sealed against the fireplace front surround.

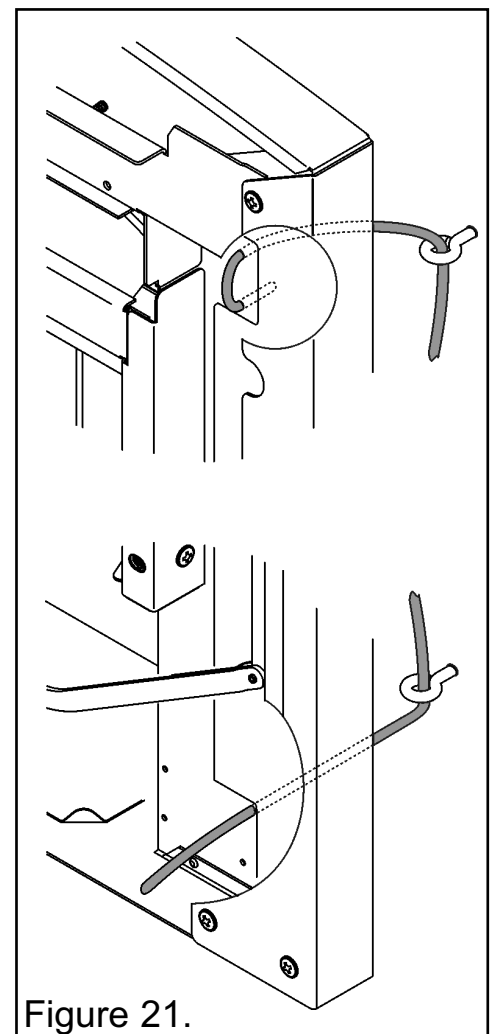
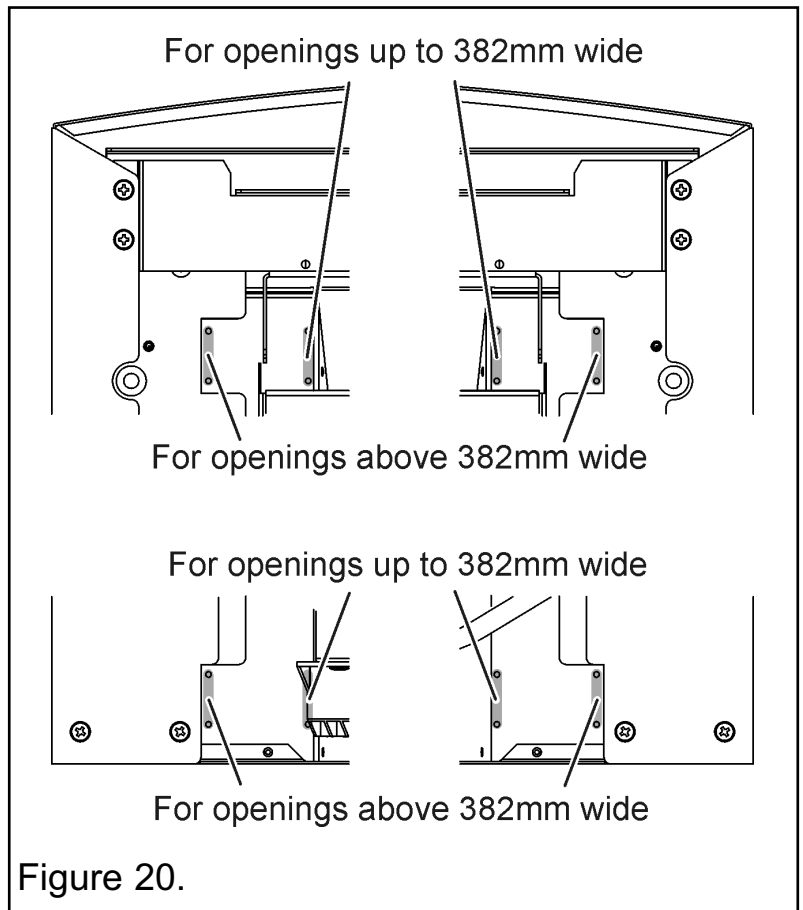

INSTALLER GUIDE

8. Drill a hole into the fireplace floor through each of the two holes in the base of the convection box using a suitably sized masonry drill for the fibre / wooden plugs supplied (See figure 22).

9. Insert a fibre / wooden plug into each hole. Use the fibre / wooden plugs supplied with this appliance - **Never use plastic plugs instead of the fibre / wooden plugs supplied.** Fit a wood screw in each plug and tighten.

Always screw the base into position before applying tension to the cables. This will ensure a tight seal between the top of the convection box and wall.

10. Fit a cable retainer over the bottom end of each cable (See figure 23).

11. Pull each cable taut. Push the cable retainers hard up against the convection box flanges. Tighten the screws in the retainers so that they clamp the cables in position. Apply tension to the cables by turning the hexagonal adjusters by hand (See figure 23).

12. Inspect the installation of the convection box against the fireplace surround. If the convection box is aligned squarely and the sealing is satisfactory, fully tighten the cable retainers.

13. Push the free length of the cables through the adjacent holes in the convection box so that they are available to allow easy removal and refitting of the appliance during subsequent service calls (See figure 23).

10.3 Floor sealing.

Using the floor sealing tape supplied, seal the bottom of the convection box to the fireplace and hearth floor (See figure 24). **DO NOT COVER THE INFORMATION LABEL.**

10.4 Sealing convection box holes.

The rear, inner sides and front flanges of the convection box have small holes and openings that will allow room air to pass into the fireplace opening / flue box opening. Although these holes are no cause for concern it is important to seal them to optimise the performance of the fire. An additional length of tape is supplied with the fire, use

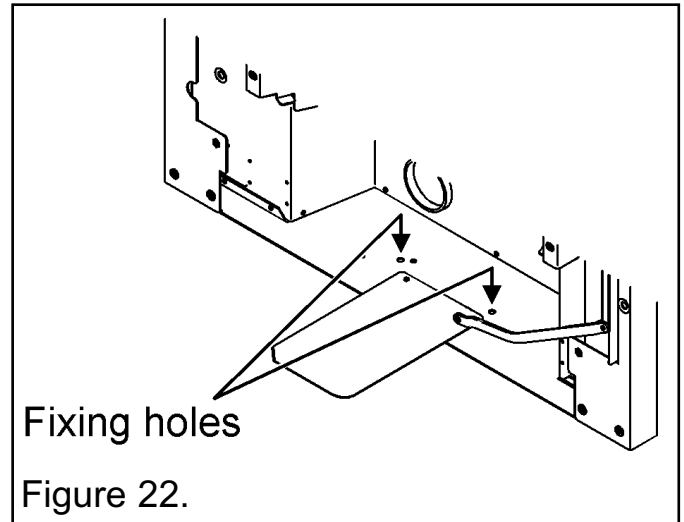

Figure 22.

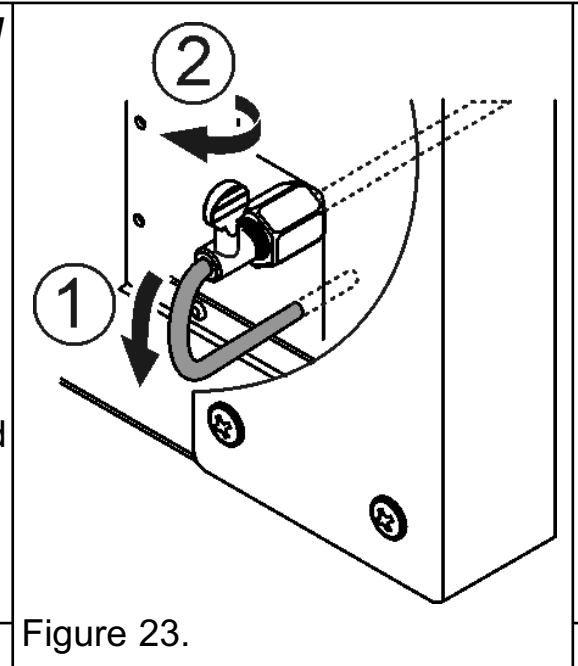

Figure 23.

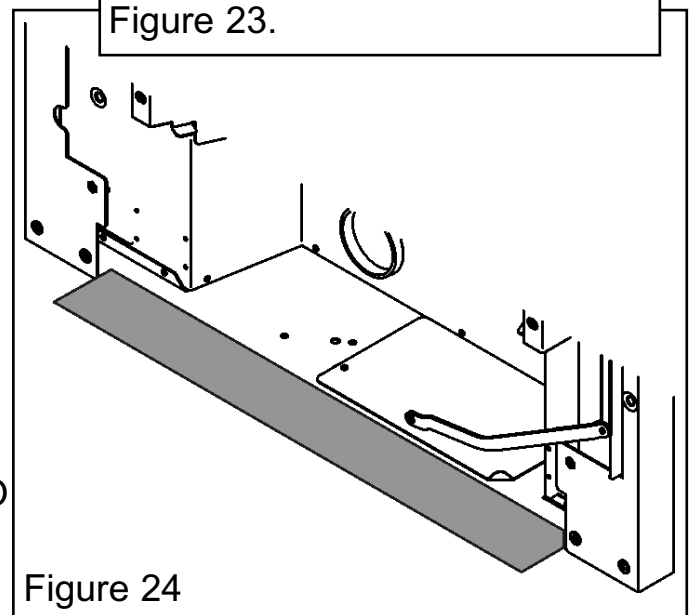

Figure 24

INSTALLER GUIDE

this to seal any holes in the rear and inner sides of the convection box. DO NOT tape over the large holes in the top of the convection box.

11. BURNER INSTALLATION

11.1 Burner and supply pipe installation.

1. Fit the burner unit to the convection box with two screws (See figure 15).
2. Align the hole near the bottom of the control linking bar with that in the control pivot bracket. Join them with the screw removed previously (Use a screwdriver - do not leave as finger tight only).
3. Check that the control linkage bar does not interfere with the appliance cable retention nuts or wires.
4. Connect the supply line to the appliance.
5. Pressure check the installation pipework for gas soundness. In the United Kingdom check in accordance with the current edition of BS6891. In the Republic of Ireland refer to the current edition of I.S. 813 "Domestic gas installations".

11.2 Preliminary burner checks.

Some burner operations can be checked at this stage. Checking now will mean that less disassembly will be required if any problems are found. A full check should still be made, however, after final installation.

11.2.1 Lighting the burner.

1. If closed, open the isolating valve at the inlet 'T' connector.
2. Depress the control knob as far as it will go and hold in this position (See section 7, figure 12). This should close the ignition circuit and (now that the gas is connected) simultaneously open the gas tap allowing the gas to flow to the pilot. Wait a few seconds while the air is purged. The electronically generated sparks should light the pilot and the burner. There may be a delay of up to four seconds between the pilot lighting and ignition of the gas at the main burner. This is normal and is due to the time required to fill the main burner compartment with sufficient gas for ignition. Keep at this position for a further 10 seconds to allow the pilot flame to stabilise.
3. Release the knob. The knob should automatically spring up to the low heat position. If for any reason the slider control does not spring up, raise the slider to the upmost position and investigate why the slider is not operating correctly.

11.2.2 Operating the burner.

1. When the burner is operating properly, gradually lift the control slider. The burner flames should gradually increase. You should feel some resistance when the slider control reaches the maximum burner flame position. Lifting further until the control slider comes to a stop should then turn the burner and pilot off. If the above checks are satisfactory, continue with the installation. If not, check the control and ignition circuitry and components as described in the servicing section of this manual.

INSTALLER GUIDE

11.3 Inlet pressure check.

The appliance is pre-set to give the correct heat input at the inlet pressure shown in section 3 of this manual. No adjustment is necessary.

1. Check the inlet pressure by fitting a pressure gauge at the test point. The test point is on the inlet 'T' connector (See figure 25). Check the pressure with the appliance alight and set at maximum output.
2. After checking, turn off the appliance. Remove the pressure gauge and replace the test point sealing screw.

When the above checks from section 11.2 and 11.3 have been completed close the isolating valve on the inlet 'T' connector.

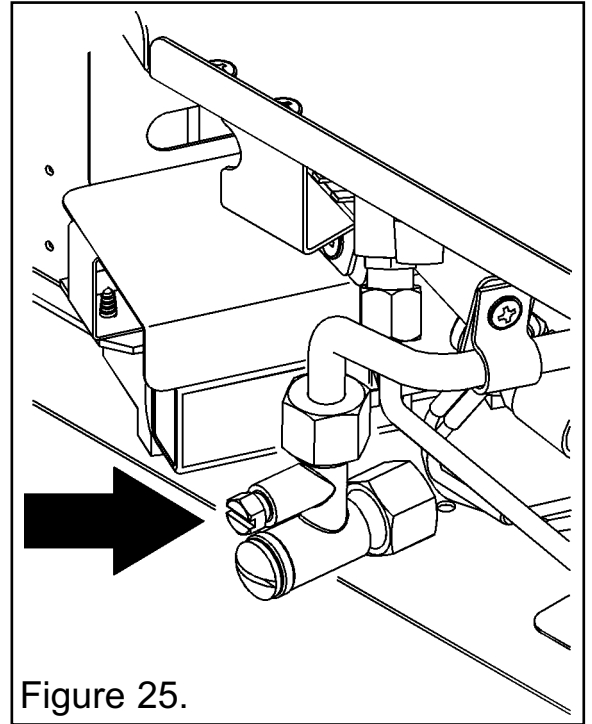

Figure 25.

12. FITTING THE CERAMIC FUEL EFFECT

The installer and owner guide for the ceramic fuel effect is supplied with the ceramic fuel effect. It is important that the fitting guide for the ceramic fuel effect be placed inside or attached to this guide and handed to the customer following completion of the 'Final review' section.

13. FITTING THE WINDOW

1. Locate the window assembly as in figure 26.

2. Apply a small amount of pressure to the base of the window assembly to overcome resistance from the window gasket. With the base of the window assembly close to the fire body insert and secure the window assembly with the two knurled screws removed previously.

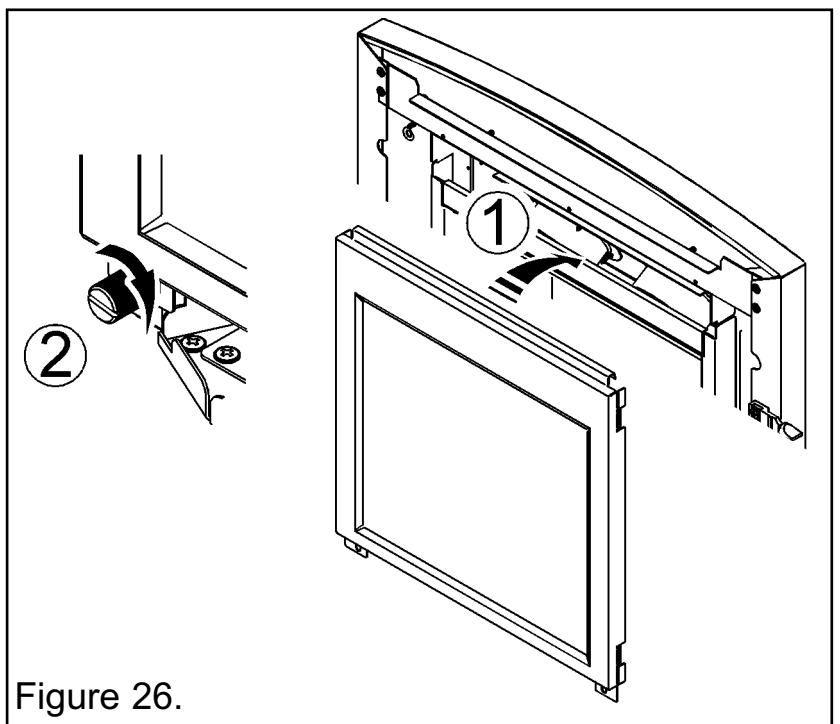

Figure 26.

INSTALLER GUIDE

14. SPILLAGE AND FLAME SUPERVISION CHECKS

14.1 Check for spillage.

A spillage check must be made before leaving the installed appliance with the customer. Make this with all the ceramic fuel effect pieces and window in position.

IMPORTANT: Only use the smoke match tube supplied with the fire. Do NOT use other smoke match tubes.

1. Open the isolating valve on the inlet 'T' connector. Test around the sealing cap and pressure test point for gas soundness with a suitable leak detection fluid.
2. Close all doors and windows in the room containing the appliance.
3. Light the appliance and set the slide control to the maximum burning position (This can be found by sliding the control knob up until a check to the slider movement is felt).
4. Leave the appliance on for five minutes.
5. Place the smoke match into the appliance outlet (See figure 27).

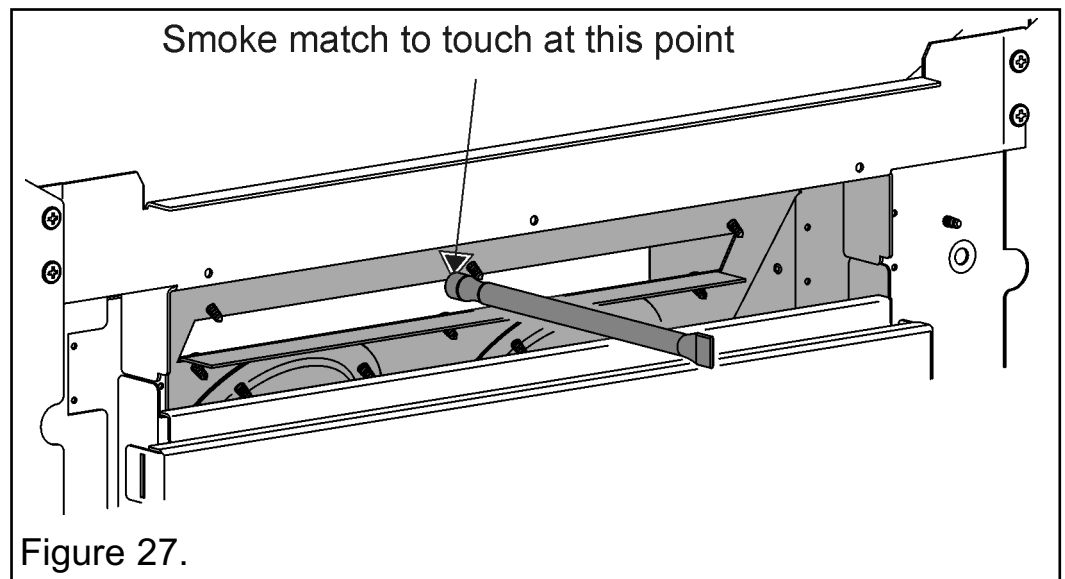

6. The installation is satisfactory if the smoke is drawn into the appliance. If the smoke is not drawn into the appliance, leave the appliance alight at the maximum setting for a further ten minutes and then repeat the test. If smoke is still not drawn into the appliance, inspect the sealing to the fireplace surround. If the sealing is satisfactory but the appliance is installed with the flue restrictor (See section 9.3), adjust the restrictor to the fully open position. To adjust the restrictor, locate the central screw at the rear of the convected air outlet (See figure 17). Loosen the screw and with the screw driver still in the head of the screw, slide the restrictor to the desired position. Secure the restrictor by tightening the screw. Retest the fire. If smoke is still not drawn into the appliance, disconnect the appliance and seek expert advice.

INSTALLER GUIDE

7. If the above test is satisfactory, open all internal connecting doors, hatches, etc., in the room. Keep all doors and windows that open to the outside of the building closed. Recheck for spillage as above. If an extractor fan is installed in the same room as the appliance or a connecting room, check that spillage does not occur with the fan operating and all doors and other openings between the fan and the appliance open. If the smoke is drawn into the appliance, continue with the installation. **If the test is not satisfactory, disconnect the appliance and advise the customer of the cause of failure.**

8. **VERY IMPORTANT: The smoke match tube must remain with the fire.** Place the smoke match tube in the recess at the bottom left hand side of the fire. A label will indicate where it is to be placed.

14.2 Flame supervision and spillage monitoring system.

This pilot unit includes a system that will automatically shut off the gas supply if the pilot flame goes out or if there is insufficient oxygen due to spillage or poor ventilation. Check that the system operates properly as follows;

1. Light the appliance. Set the slide control to the maximum burning position (This can be found by sliding the control knob up until a check to the slider movement is felt) and leave for one minute.
2. Set the control to the 'Low' burning position. Isolate the gas supply at the inlet 'T' connector. The pilot and main burner will go out. **Note the time when the pilot goes out.** Listen for a snap sound at the gas tap. **Note the time when the sound is heard.** This sound is caused by an electromagnetic valve shutting off the gas supply through the tap. The valve is located in the body of the tap. The valve should operate **within 60 seconds of the pilot going out.** If the valve does not operate within this time limit do not allow the appliance to be used until the fault has been corrected. **This monitoring system must not be adjusted, bypassed or put out of operation.**
- This monitoring system, or any of its parts, must only be exchanged using authorised parts.**
3. Open the isolating valve on the inlet 'T' connector. Screw on the end cap and test for gas soundness using a suitable leak detector.
4. Set the slider to the upmost position to turn the fire off.

INSTALLER GUIDE

15. FITTING THE HEAT BAFFLE

1. The fire is supplied with a heat baffle. Locate the heat baffle to the top of the fire as shown in figure 28. **Note:** Dream/Masquerade/Excelsior use the same heat baffle.

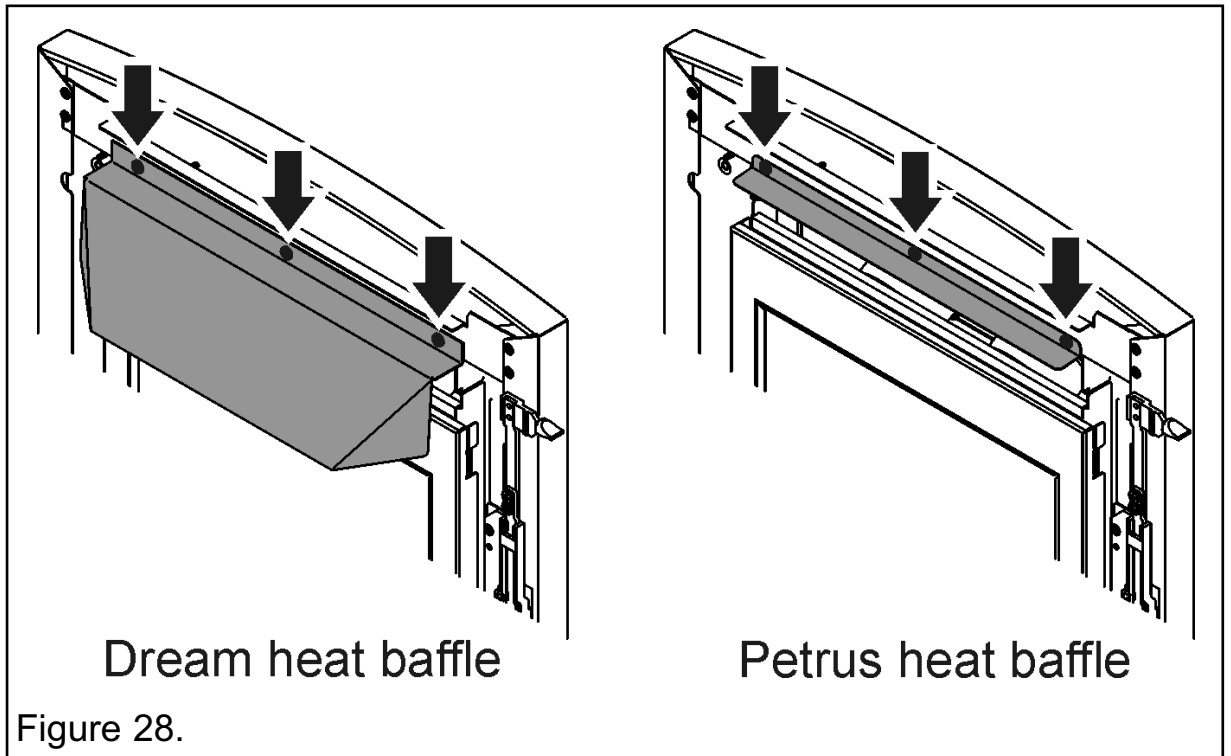

16. FITTING THE FASCIA

16.1 Dream/Masquerade/Excelsior and Petrus models.

1. Locate the hanging brackets on the rear of the fascia onto the support bar at the top of the fire (See figure 29).

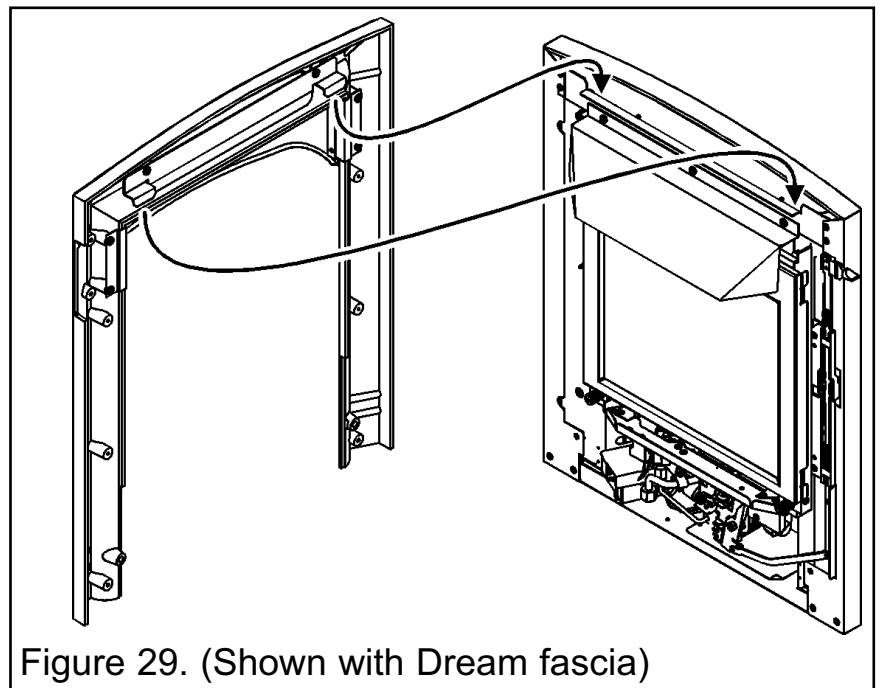

INSTALLER GUIDE

2. Secure the bottom of the fascia unit to the convection box with two M4 x 25mm screws and washers (See figure 30).

16.2 Petrus model.

1. The Petrus fascia has a louvre assembly (See figure 9 - Pack 1, contents).

2. Carefully locate the louvre assembly onto the brackets at the top of the fascia (See figure 31). Be careful not to damage the paint finish on the firefront.

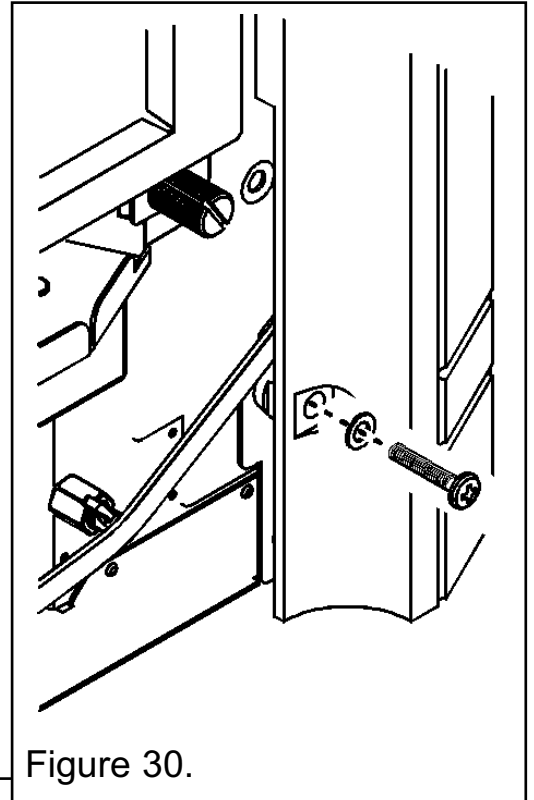

Figure 30.

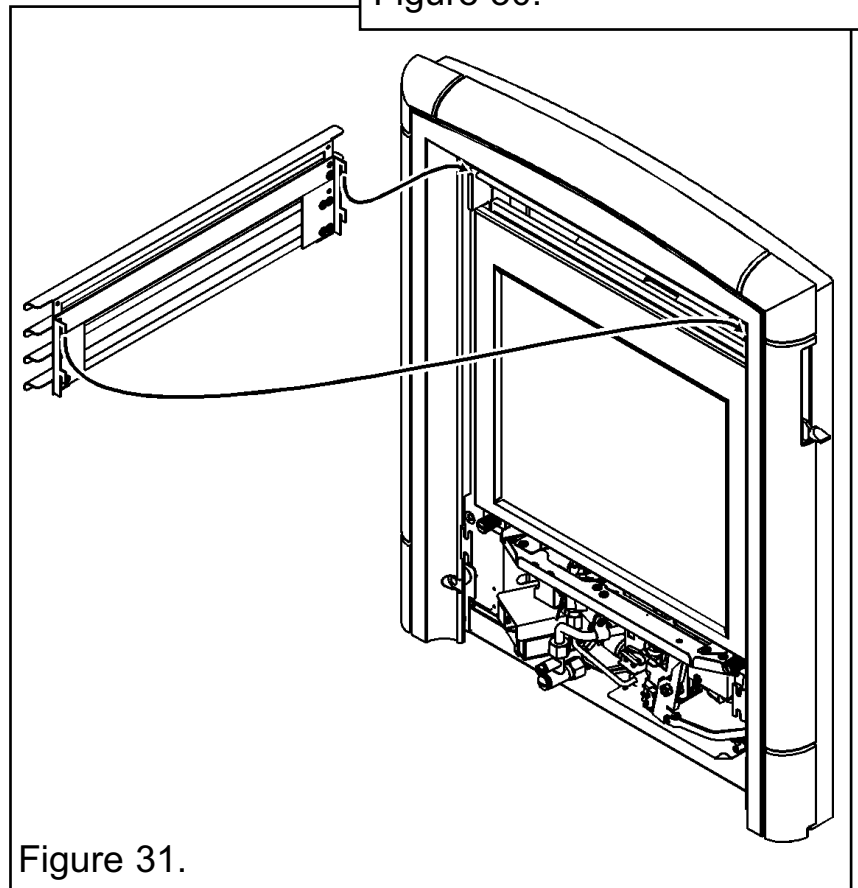

Figure 31.

17. FIREFRONT CASTING INSTALLATION

17.1 Fitting the Petrus rear screen assembly.

The assembly instructions are contained in the fascia pack.

17.2 Fitting the Petrus fire front casting.

1. Remove the fire front from its packaging.
2. The rear of the fire front may be fitted with hanging screws or they may be supplied in the fire front packaging. Where they are not already fitted insert them into the lower holes on both sides of the firefront. The distance between the firefront and the underside of the screw heads should be approximately 10mm. The screws can be adjusted to obtain the required fit (See figure 32).
3. Hang the firefront on the keyhole slots on the heater (See figure 33).
4. Position the ash pan cover beneath the firefront.

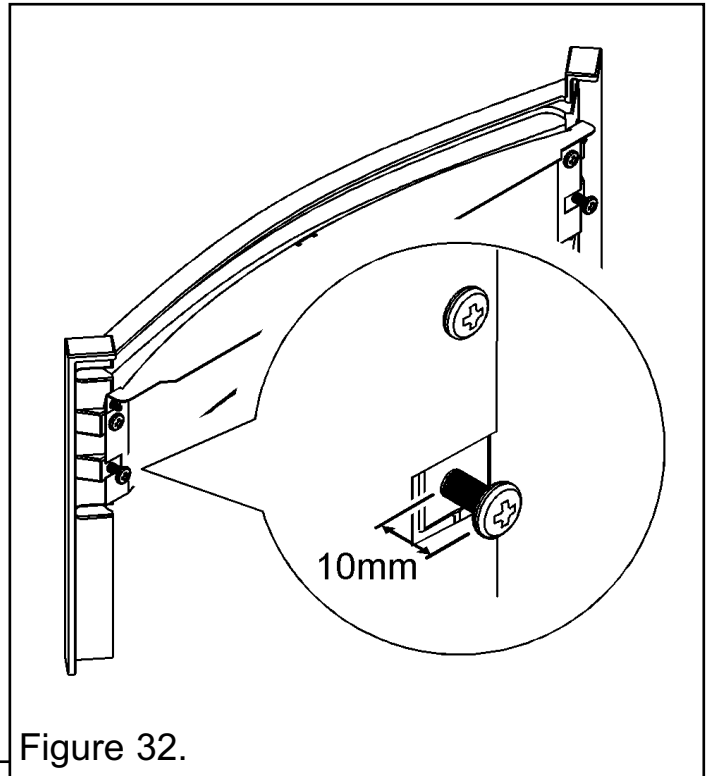

17.3 Fitting the Dream/Masquerade/Excelsior rear screen.

The assembly instructions are contained in the fascia pack.

17.4 Fitting the Dream/Masquerade/Excelsior firefront casting.

1. Place the firefront casting centrally on the hearth in front of the fascia.
2. Place the bottom front cover casting in position below the firefront casting.

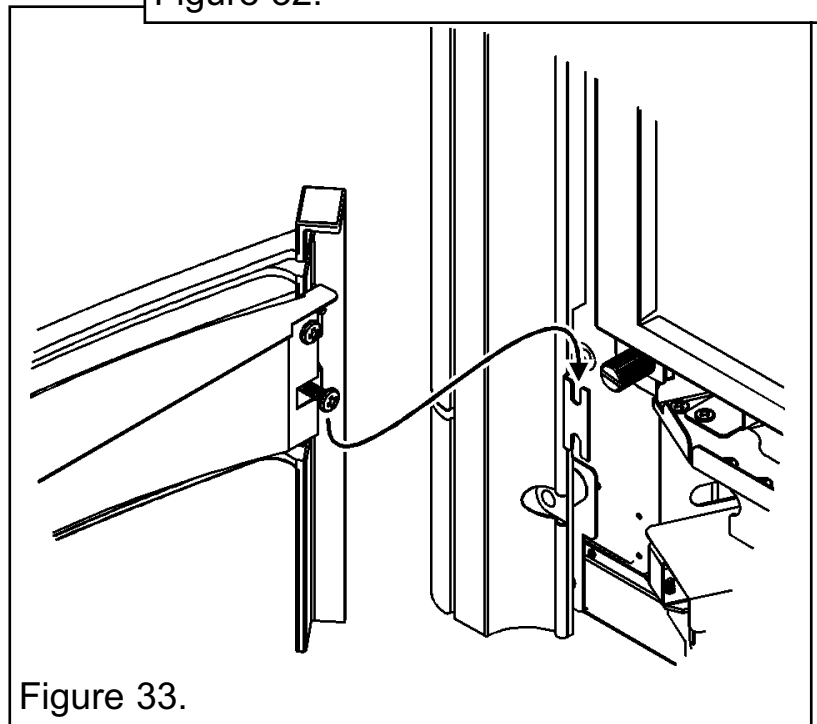

18. FULL OPERATING CHECKS

18.1 Recheck the control settings.

The control position markings on the fascia are shown in figure 34.

Please note:

- When first turned on from cold, the flames will appear predominantly blue.
- When operating the fire for the first time, some vapours may be given off which could set off smoke alarms in the vicinity. These vapours are quite normal with new appliances. They are totally harmless and will disappear after a few hours use.

18.2 Lighting the burner.

1. Make sure the slider knob is at the 'OFF' position.
2. Slide the knob to the bottom (ignition) position marked



. Retain in this position to ignite the pilot. The burner

should ignite at its lowest setting within 4 seconds of the pilot igniting. Keep at this position for a further 10 seconds to allow the pilot flame to stabilise.

3. Release the knob. The knob should automatically spring up to the low heat position. If for any reason the slider control does not spring up, raise the slider to the 'OFF' position and investigate why the slider is not operating correctly. If the flames go out at this stage or when checking the rest of the setting positions, try the full lighting sequence again. If the flames fail after two attempts, investigate the pilot unit.

18.3 Operating the burner.

1. Gradually slide the knob up to increase the burner setting. The burner should be at its maximum setting at the high heat position shown in figure 34. You should feel a check to the knob movement at this position.
 2. Slide the control knob up past the high heat position to the 'OFF' position at the top of the slide slot. Both pilot and main burner should go out.
- While cooling the ceramic fuel effect pieces may make some crackling noises. This is quite normal.

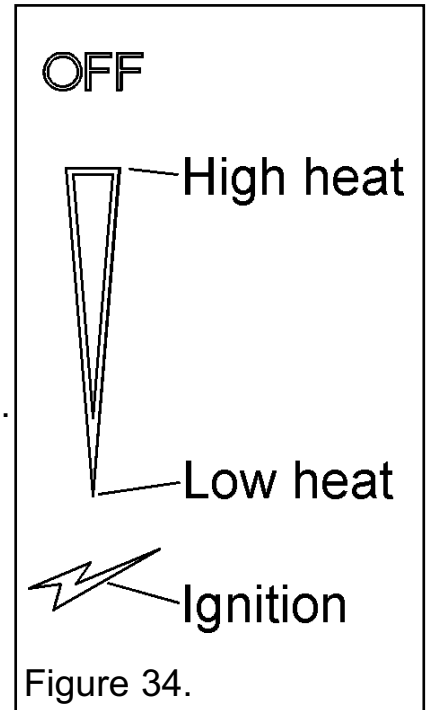

Figure 34.

INSTALLER GUIDE

19. FINAL REVIEW

- 1. COMPLETE THE INFORMATION IN THE WARRANTY AND SERVICE SECTION OF THE OWNER GUIDE (See last pages of the OWNER guide).**
2. Visually inspect the appliance. Clean off any marks incurred during installation.
3. Advise the customer how to operate the fire.
4. Explain to the customer that the appliance has a flame failure and spillage monitoring system. Point out the explanation of this system shown in the owner guide. Advise that if the fire goes out for any reason, wait at least three minutes before relighting. Stress that if the monitoring system repeatedly shuts off the fire, the appliance should be switched off and a competent person should be consulted.
5. Advise that the fire may give off a slight odour while new. This is quite normal and it will disappear after a few hours of use.
6. Advise that any cleaning must only be carried out when the fire is off and cold.
7. Advise the customer that they should read the owner guide before operating the fire and always follow the advice in the section headed "Cleaning your fire".
8. Advise the customer that the appliance will operate to its maximum potential if the flue is primed during the first 20 – 30 minutes of use. To do this, simply set the control to its highest setting. This will also burn off any carbon deposits that may have formed during previous use.
If using the appliance for long periods it is beneficial to change between settings. This will also help to remove any carbon deposits that may form during use.
9. Recommend that the appliance should be serviced and the chimney inspected by a competent person at least annually.
If the appliance is in premises in the United Kingdom occupied by a tenant, point out that by law a landlord must have any gas appliance, flue and pipework which is situated in a tenant's premises checked for safety at least every 12 months.
10. Advise the customer that the fascia, window and ceramic pieces can be cleaned as described in the owner guide and that the loose ceramic fuel effect pieces must be replaced as described in the instructions supplied with them.
Stress that no extra ceramic fuel effect pieces must be added over and above those supplied with the appliance and that any replacements must only be the authorised spares. Warn that ignoring this advice could cause incomplete clearance of the products of combustion with consequent health hazards.
11. Inform the customer that the Serial number for the appliance is located on the information label, located behind the lower front casting and underneath the burner (See figure 8 on page 62).
12. Hand the literature pack with this guide to the customer.

20. SERVICING & PARTS REPLACEMENT

- Always turn off the gas supply and allow to cool completely before commencing any servicing (The appliance inlet “T” connector incorporates an isolating valve).
- It is recommended that, at least once a year, the appliance is disconnected and the fireplace opening checked and cleared of any debris.
- This product uses fuel effect pieces and a burner compartment wall containing Refractory Ceramic Fibres (RCF), which are man-made vitreous silicate fibres. Excessive exposure to these materials may cause irritation to eyes, skin and respiratory tract. Consequently, it is important to take care when handling these articles to ensure that the release of dust is kept to a minimum. To ensure that the release of fibres from these RCF articles is kept to a minimum, during installation and servicing we recommend that you use a HEPA filtered vacuum to remove any dust and soot accumulated in and around the fire before and after working on the fire. When replacing these articles we recommend that the replaced items are not broken up, but are sealed within a heavy duty polythene bag, clearly labelled as RCF waste. RCF waste is classed as a stable, non-reactive hazardous waste and may be disposed at a landfill licensed to accept such waste. Protective clothing is not required when handling these articles, but we recommend you follow the normal hygiene rules of not smoking, eating or drinking in the work area and always wash your hands before eating or drinking.
- This appliance does not contain any component manufactured from asbestos or asbestos related products.
- Check that the appliance is clean and that soot or debris is not blocking the gaps between the ceramic fuel effect pieces causing an imperfect flame.
- Ensure that the metal gauze around the pilot and injector are clear of lint and dust.
- Check that soot or debris is not impairing the electrode spark or pilot burner.
- Check that soot or debris is not blocking any of the holes in the main burner.
- After servicing, make sure that the ceramic rear wall and ceramic fuel effect pieces are replaced correctly as described in the installer and owner guide supplied with the ceramic fuel effect. The installer and owner guide supplied with the ceramic fuel effect should be placed inside or attached to this guide.
- Always test for gas soundness and spillage after servicing the appliance.

INSTALLER GUIDE

20.1 Checking the aeration setting of the burner.

1. The aeration shutter is factory set. It is important to ensure that the aeration setting is correct (See figure 35).
2. To adjust the aeration setting loosen the two aeration shutter screws, slide the aeration shutter to the desired position and tighten the fixing screws.

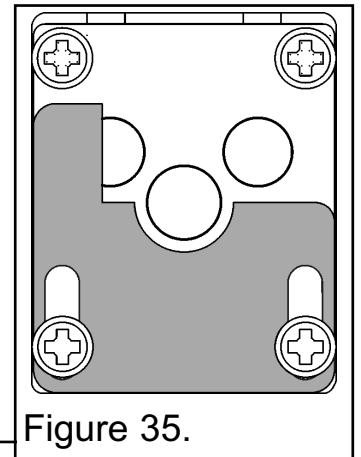

Figure 35.

20.2 To remove the ignition microswitch.

(See figures 36).

1. Remove the firefront casting and the front cover casting.
2. Disconnect the leads from the ignition microswitch (The lower of the two microswitches - See figure 36).
3. Detach the microswitch and insulation pad by removing two screws.
4. Replace in the reverse order.
5. Check that the microswitch operates correctly by fully closing it and observing that there are sparks at the pilot electrode.

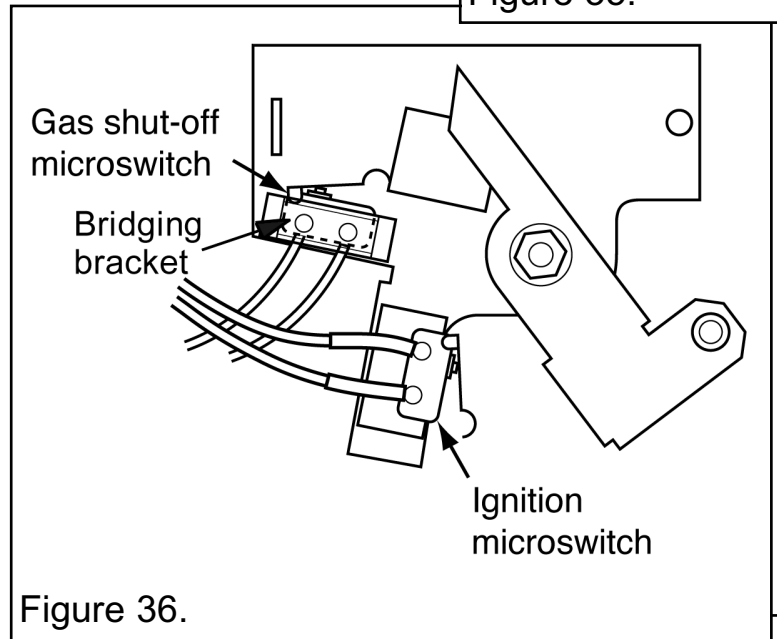

Figure 36.

20.3 To remove the gas shut-off microswitch.

(See figures 36 & 37).

1. Remove the firefront casting and the front cover casting.
2. Loosen the thermocouple nut to free the microswitch leads and pull the leads clear of the thermocouple interrupter block (See figure 37).
3. Detach the bridging bracket, microswitch assembly by removing two screws (See figure 36).
4. Replace in the reverse order. When refitting the leads to the interrupter block, make sure that they are secured firmly to give a good electrical contact. Do not over tighten the nut.

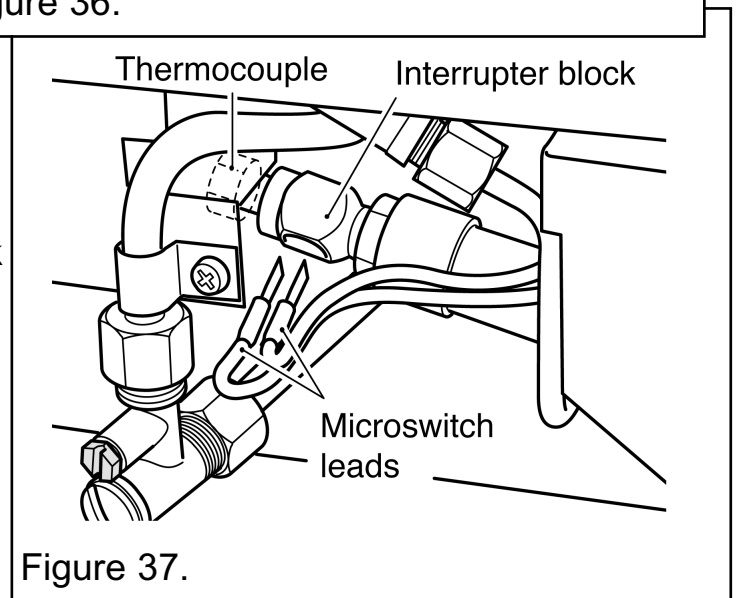

Figure 37.

INSTALLER GUIDE

20.4 To remove the fascia.

1. Remove the firefront casting and the front cover casting.
2. Remove the two screws and washers securing the bottom of the fascia to the sides of the convection box.
3. Carefully lift the fascia upward to clear the upper support bracket on the convection box (See figure 38). Pull the fascia clear and place carefully aside.
4. Refit in the reverse order. Make sure that the fascia is properly located over the upper support bracket. See section 16 of this guide for detailed fitting instructions.

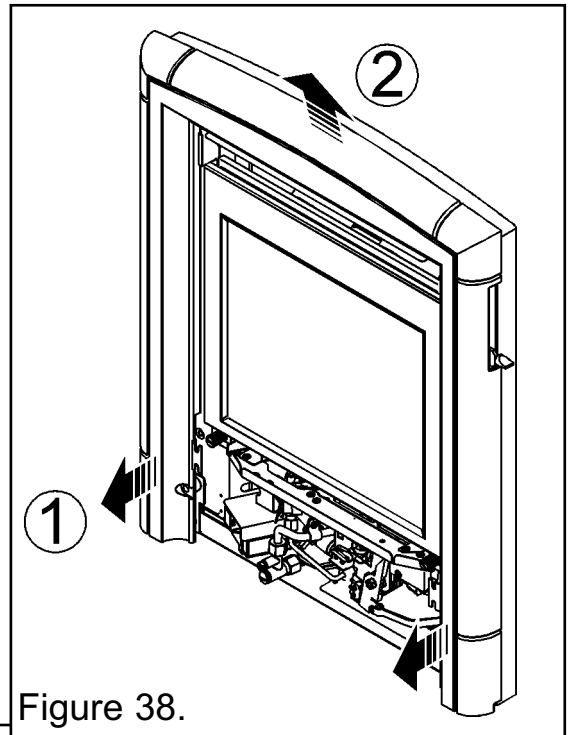

Figure 38.

20.5 To remove the window.

1. Remove the firefront casting and the front cover casting.
2. Detach and remove the window assembly. To do this unscrew and remove the two thumbscrews at the base of the window assembly. Gently lift the window assembly upward and forward (See figure 39). Place the window assembly and thumbscrews in a safe place away from the work area.

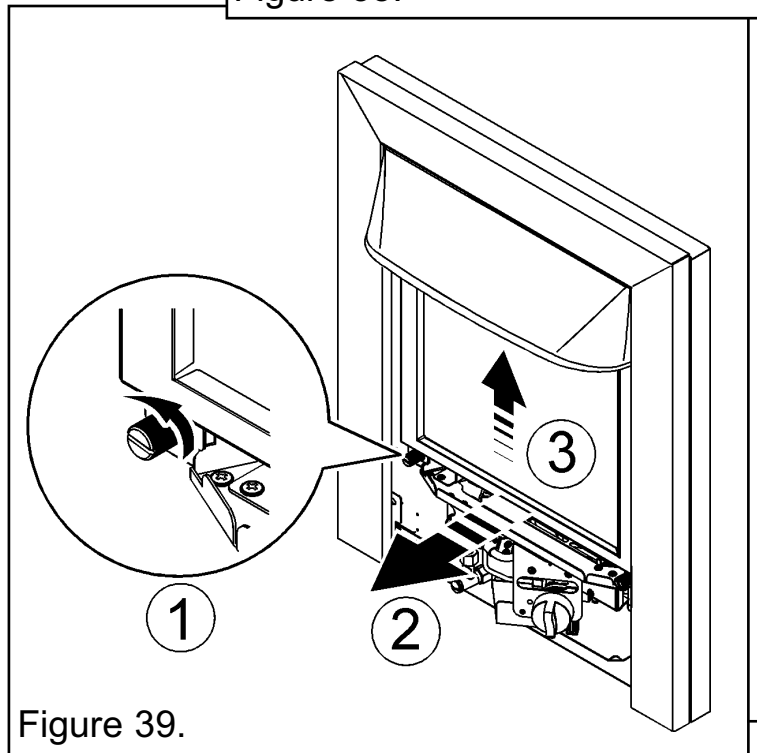

Figure 39.

20.6 To remove the burner unit.

1. Remove the firefront casting and the front cover casting.
2. Remove the loose ceramic fuel effect.
3. Support the inlet 'T' connector to avoid straining the pipework and disconnect the appliance from the inlet 'T' connector.
4. Unscrew and remove the screw that secures the slider arm assembly to the burner.
5. Detach the burner unit from the convection box by removing two screws (See figure 40).
6. Replace in the reverse order (When fitting the screw that connects the control slider to the burner use a screwdriver - do not leave as finger tight only).

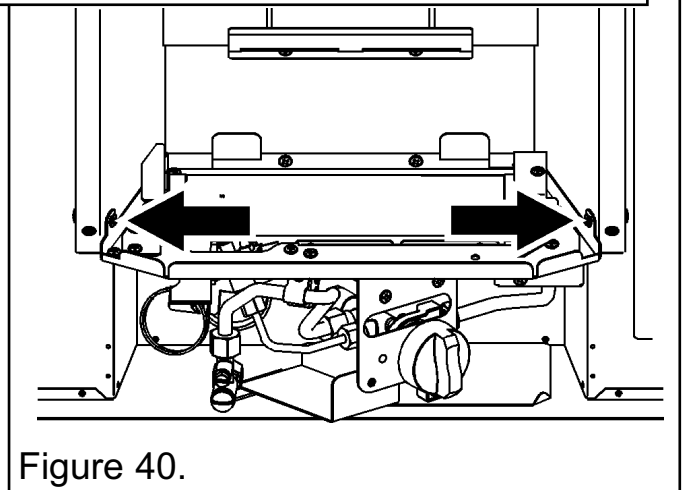

Figure 40.

INSTALLER GUIDE

20.7 To replace the control slide knob.

1. Remove the fascia (See section 20.4)
2. Detach the control slide knob by removing two screws.
3. Replace in the reverse order.

20.8 To remove the electronic ignition generator.

1. Remove the burner unit (See section 20.6)
2. Remove the battery.
3. Remove the spark lead and microswitch leads remembering to make note of their positions.
4. Unscrew the two fixing screws that attach the generator unit to the support bracket. The igniter generator can now be removed (See figure 41).
5. Replace the generator
6. Refit in the reverse order.

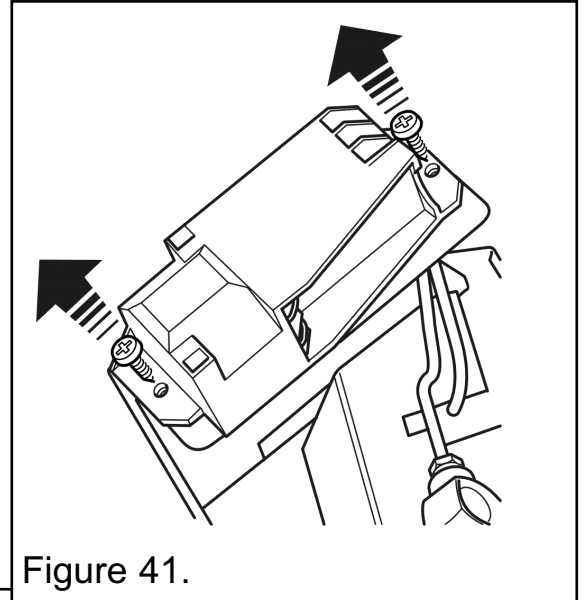

Figure 41.

20.9 To remove the thermocouple interrupter block.

(See figure 42).

1. Remove the burner unit (See section 20.6).
2. Detach the thermocouple from the interrupter block by unscrewing the thermocouple nut.
3. Detach the two microswitch leads from the interrupter block.
4. Remove the interrupter block by unscrewing from the gas shut-off tap.
5. Refit in the reverse order. If the microswitch leads cannot be easily attached to the interrupter block when it is fully tightened to the gas shut-off tap, slacken it and rotate to allow the leads to be fitted. Retighten making sure that the leads remain in place in the interrupter block. Fit and tighten the thermocouple nut making sure that the leads are secured in the interrupter block to give a good electrical contact. Do not over tighten the nut.

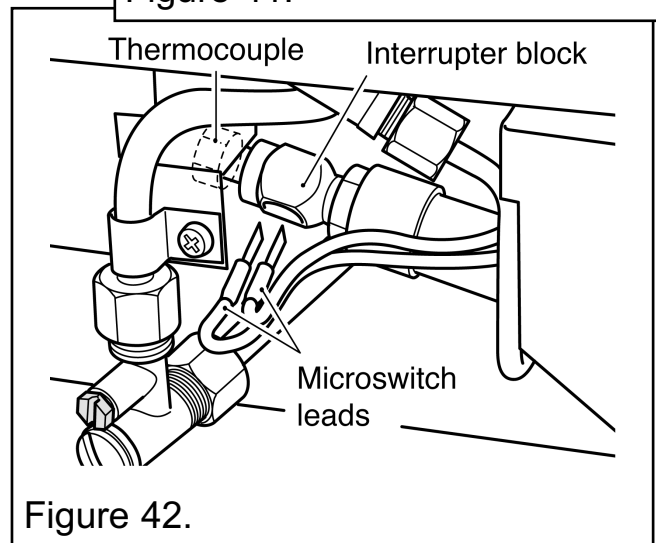

Figure 42.

INSTALLER GUIDE

20.10 To remove the pilot unit.

1. Remove the burner unit (See section 20.6).
2. Detach the pilot pipe from the pilot unit.
3. Detach the thermocouple from the interrupter block by unscrewing the thermocouple nut.
4. Detach the electrode lead from the underside of the electrode tab.
5. Remove the two screws securing the pilot unit (See figure 43).
6. Refit in the reverse order.

Note:

1. The pilot unit is an atmosphere sensing device. It must be replaced as a whole assembly. Its individual components are not separately replaceable.

2. When the thermocouple is removed from the interrupter block, the microswitch lead terminals in the interrupter block will be loose. Make sure that they are properly secured to give a good electrical contact when tightening the thermocouple nut. Do not over tighten the nut.

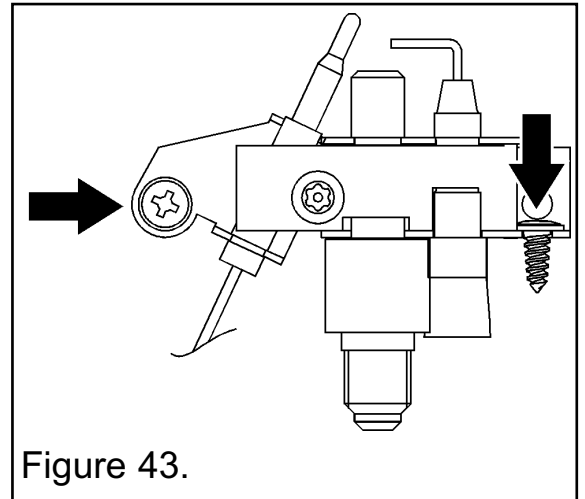

Figure 43.

20.11 To remove the shut-off tap.

(See figure 44).

1. Remove the burner unit (See section 20.6).
2. If lying the burner on its back, ensure that the work surface is suitably protected. This will avoid damage to the work surface. Turn the burner unit upside down. Detach the thermocouple and interrupter block from the tap (See section 20.9 paragraphs 2 - 4).
3. Detach the pilot pipe from the tap.
4. Detach the inlet pipe.
5. Remove the hexagonal nut securing the tap to the mounting bracket.
6. Detach the elbow by unfastening the hexagonal nut connecting it to the flow rate controller. Lift the tap (complete with elbow) clear.

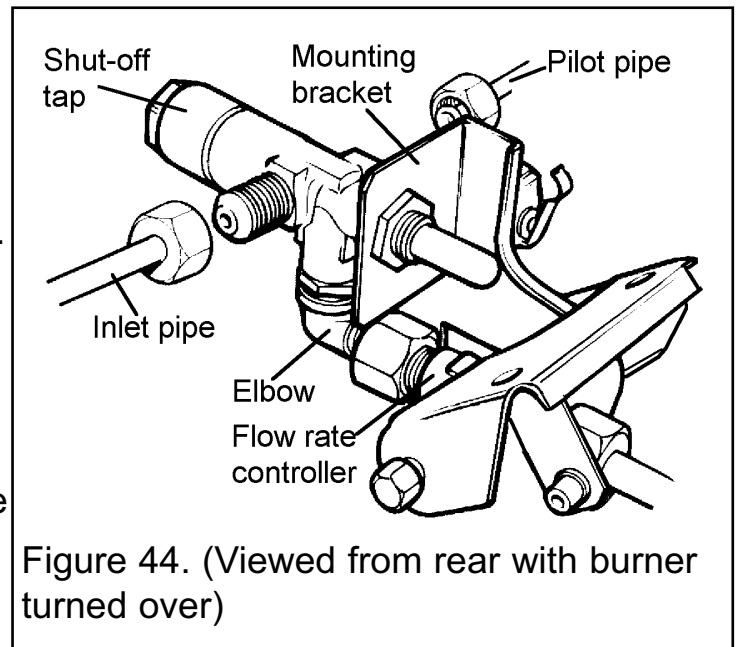

Figure 44. (Viewed from rear with burner turned over)

7. Loosen the hexagonal locknut securing the elbow to the tap. Remove the elbow by rotating it.
8. If fitting a new tap, remove the hexagonal nut at the mounting bracket end of the old tap and fit to the replacement tap. Refit in the reverse order. The joint between the elbow and tap should have a suitable thread sealant applied to prevent leaks (This must have a constant working temperature of at least 80°C). When refitting, make

INSTALLER GUIDE

sure that the tap spindle is in the correct relationship relative to the control pivot bracket. Rotate the pivot bracket fully clockwise. The tap spindle should “bottom out” (i.e. the tap should be fully open) after the pivot bracket has actuated the ignition microswitch but before it has pushed the microswitch leaf against the microswitch body.

When refitting the thermocouple and interrupter block, make sure that the microswitch wires are properly secured to give a good electrical contact. Do not over tighten the nut.

20.12 To remove the gas flow rate controller.

(See figure 45).

1. Remove the burner unit (See section 20.6).
2. If lying the burner on its back, ensure that the work surface is suitably protected. This will avoid damage to the work surface.
3. Detach the shut-off tap as detailed in section 20.11 paragraphs 2-6.
4. Detach the burner pipe from the controller. Support the controller while detaching to prevent excessive strain.
5. Remove the nut and washer securing the control pivot bracket to the controller at the front. Support the pivot bracket while removing the nut to prevent possible damage to the microswitch.
6. Remove the hexagonal bolt securing the control pivot bracket to the controller at the rear.
7. Detach the control pivot bracket.
8. Remove the hexagonal nut securing the controller to the front mounting bracket and remove the flow rate controller.
9. Refit in the reverse order.

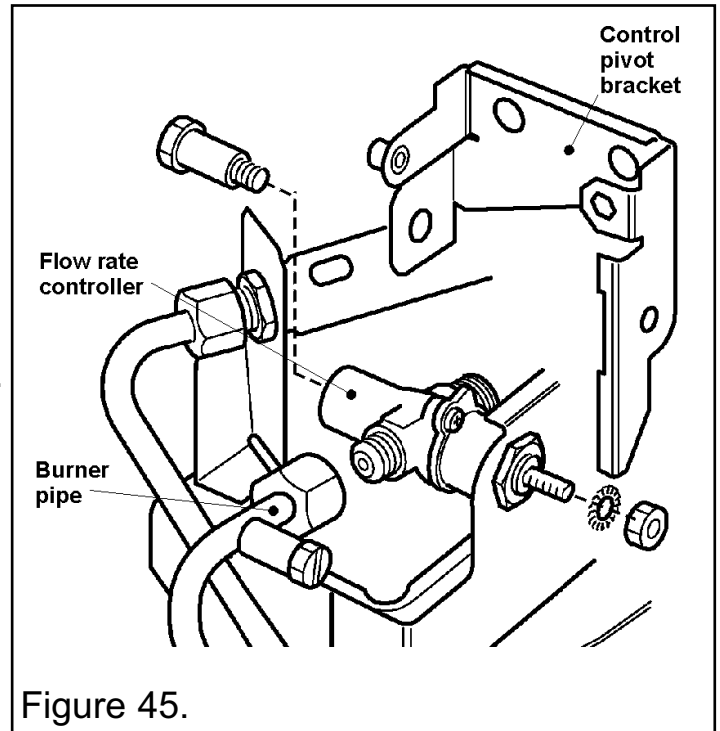

Figure 45.

20.13 To remove the burner.

1. Remove the burner unit (See section 20.6).
2. Remove the metal gauze from around the injector. To do this unscrew and remove the screw from the front of the burner tray.
3. Support the elbow injector and unscrew the injector nut.
4. Remove the two screws from the burner clamping plate (See figure 46)
5. Lift the right hand side of the burner, slide it to the right and lift clear.
6. Refit in reverse order.

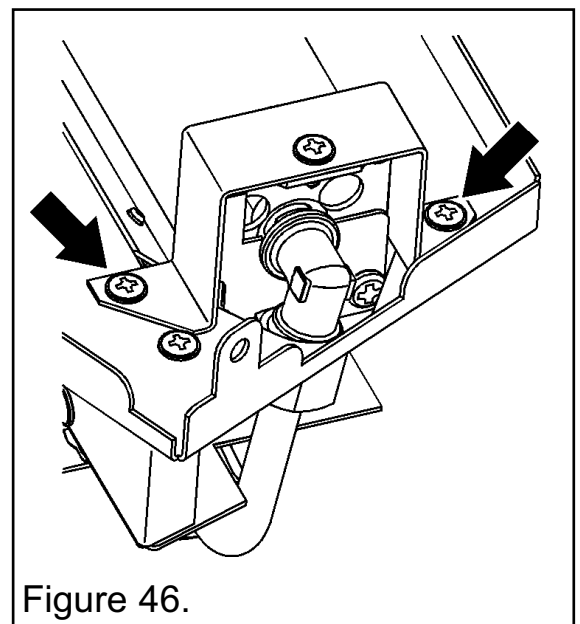

Figure 46.

INSTALLER GUIDE

20.14 To remove the main burner injector.

1. Remove the burner (See section 20.13, paragraphs 1-4).
2. Remove the burner clamping screw (See figure 47)
3. Unscrew the injector from the burner
4. Refit in the reverse order.

20.15 To remove the appliance from the fireplace.

1. Remove the burner unit (See section 20.6).
2. If the fire retention is as method 1 remove the fixing screws.

If the fire retention is as method 2 (See section 10.2 of installation instructions), slacken the hexagonal adjusters on the cable retainers and unscrew the thumbscrews to release the cables. Unscrew and remove the screws from the base of the convection box.

3. Refit as described in the relevant installation sections. Make sure gas soundness, sealing, spillage test and performance are satisfactory.

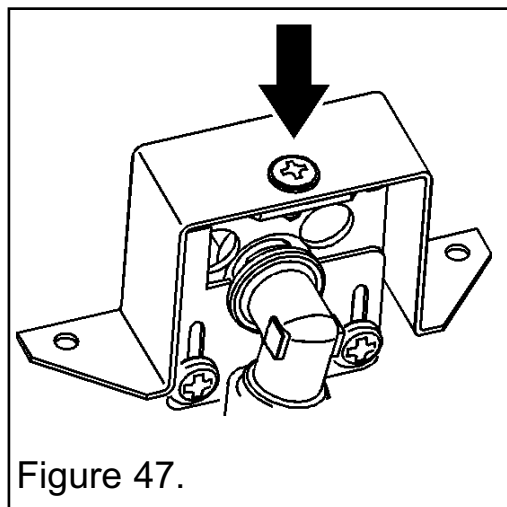

OWNER GUIDE

FOR WARRANTY AND SERVICE INFORMATION
SEE PAGES 60 TO 64

OWNER GUIDE

LIST OF CONTENTS

<u>Section</u>	<u>Page</u>
IMAGES	49
SAFETY	50
APPLIANCE DIMENSIONS	52
GAS CONSUMPTION	53
OPERATING YOUR FIRE	53
The Oxysafe flame sensing and flue blockage safety system.	53
Lighting the pilot.	54
Lighting with a taper.	55
HELP AND ADVICE	56
Ignition - Lighting the fire.	56
Window - Glass.	56
Fuel effect - Coal bed.	56
The rear wall effect.	56
The reflective sides and top inside the fire.	57
CLEANING YOUR FIRE	57
Metal Parts.	57
Window cleaning and removal.	57
To clean the front of the window.	57
To clean the inside of the window.	57
Ceramic fuel effect and rear wall.	58
Burner.	58
CERAMIC FUEL EFFECT REFITTING	58
MAINTENANCE	59
Battery replacement.	59
Regular maintenance.	59
Replacement ceramics.	60
WARRANTY, SERVICE AND BENCHMARK	60-63
BENCHMARK COMMISSIONING CHECKLIST	62
BENCHMARK SERVICE RECORD	63
SERIAL NUMBER LABEL	64

This gas fire is designed to meet the most stringent quality, performance and safety requirements to provide you with many years' trouble-free service.

This guide aims to improve your understanding and appreciation of your gas fire by providing simple and informative instructions to ensure that you benefit from the excellent performance and features it has to offer.

IMAGES

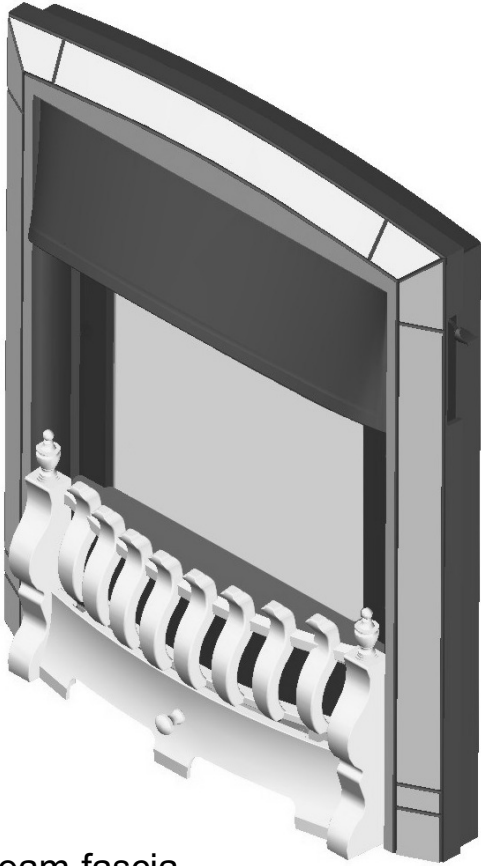

Dream fascia

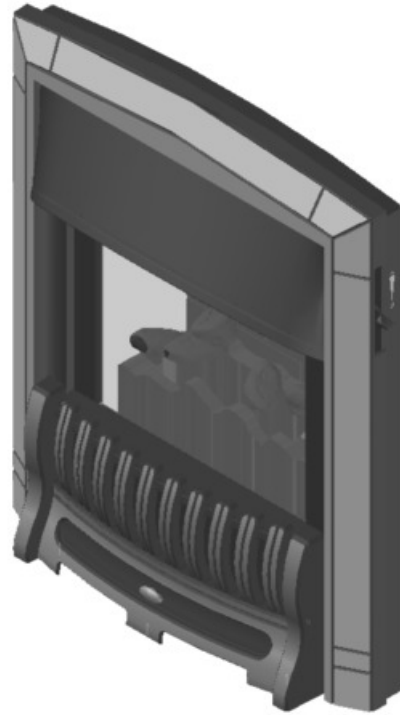

Excelsior fascia

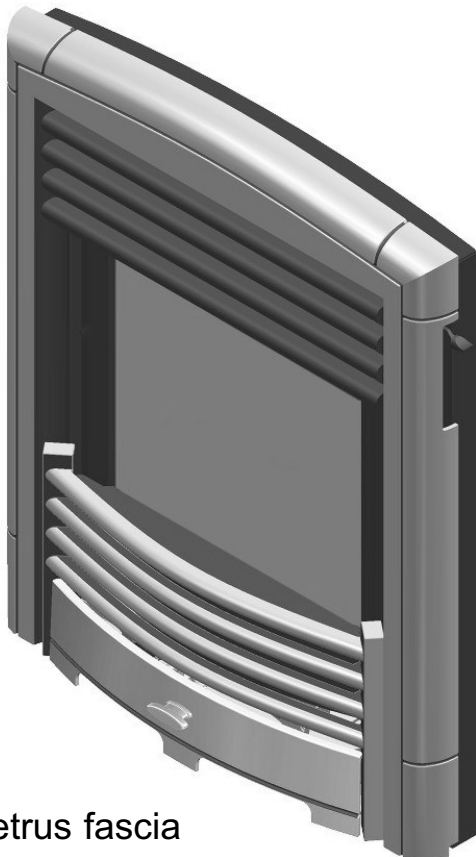

Petrus fascia

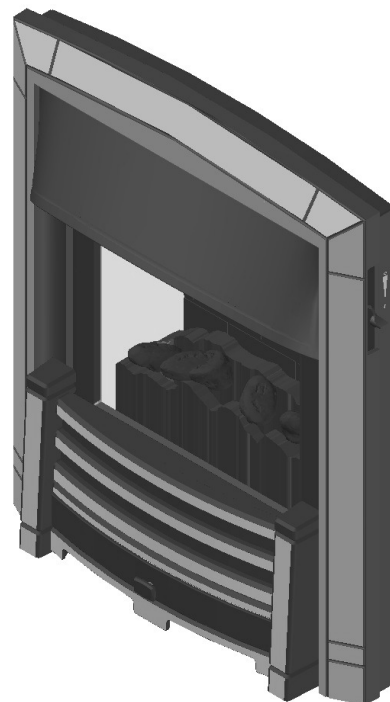

Masquerade fascia

OWNER GUIDE

SAFETY

IF YOU SMELL GAS

- **DON'T SMOKE.**
- **EXTINGUISH ALL NAKED FLAMES.**
- **DON'T TURN ELECTRICAL SWITCHES ON OR OFF.**
- **TURN OFF THE GAS SUPPLY AT THE METER.**
- **OPEN DOORS AND WINDOWS TO GET RID OF THE GAS.**
- **IMMEDIATELY CALL THE GAS EMERGENCY SERVICE FROM A NEIGHBOURS PHONE - SEE YOUR LOCAL TELEPHONE DIRECTORY.**

Do have the fire installed by a competent person. In the United Kingdom, installation must be in accordance with the latest edition of the Gas Safety (installation & use) Regulations. In the Republic of Ireland, installation must be in accordance with all national and local regulations in force.

Do have the chimney swept prior to installation if it was previously used for solid fuel.

Do have the fire installed in accordance with the installer guide.

Do provide the minimum height from the base of the fireplace opening to the underside of any shelf made from wood or other combustible materials as detailed below:

For Homeflame Dream/Masquerade/Excelsior models -

- *For a shelf up to 150mm deep: Minimum height = 700mm.*
- *For a shelf deeper than 150mm: 700mm + 12.5mm for every 25mm depth over 150mm (See Figure 1).*

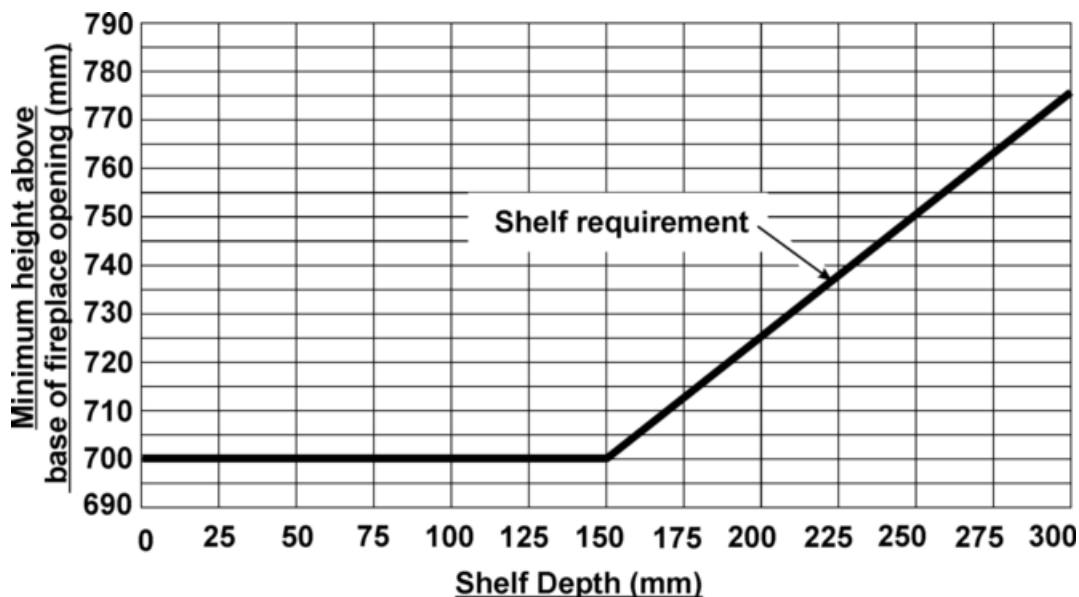

Figure 1. Combustible shelf clearances

OWNER GUIDE

For Homeflame Petrus models -

- For a shelf up to 150mm deep: Minimum height = 750mm.
- For a shelf deeper than 150mm: 750mm + 12.5mm for every 25mm depth over 150mm (See Figure 2).

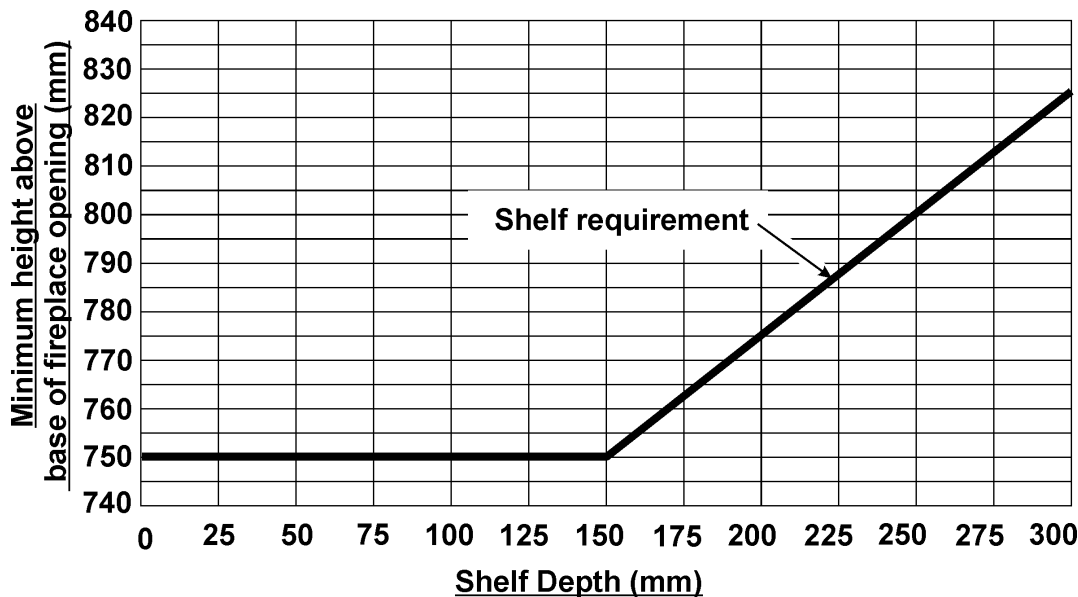

Figure 2. Combustible shelf clearances

Do always use a fireguard complying with BS 8423 for the protection of young children, the elderly or infirm.

Do wait three minutes before attempting to relight if the fire is switched off or the flames are extinguished for any reason (Your fire is fitted with a safety device that will automatically shut off the gas supply to the fire, if for any reason, the flame goes out).

Do get advice about the suitability of any wall covering near your fire. Soft wall coverings (e.g. embossed vinyl, etc.) which have a raised pattern are easily affected by heat. They may, therefore, scorch or become discoloured when close to a heating appliance. Please bear this in mind whenever you are considering redecorating.

Do provide a minimum side clearance as detailed in figure 3. Please bear this in mind if ever you are altering the room.

Don't hang clothing, towels or any other fabrics over the fire.

Don't put more ceramic fuel effect pieces on the fire than the number given in this guide or use any ceramic fuel effect pieces other than those authorised for this fire. This could cause incomplete combustion and subsequent safety hazard.

Don't put paper or other materials onto your fire.

Don't use the fire with damaged base ceramics.

Don't place any combustible material (rugs, carpet, plastic tiles, etc.) on the hearth.

Don't attempt to clean or service the fire until it has been switched off and allowed to cool completely.

OWNER GUIDE

APPLIANCE DIMENSIONS

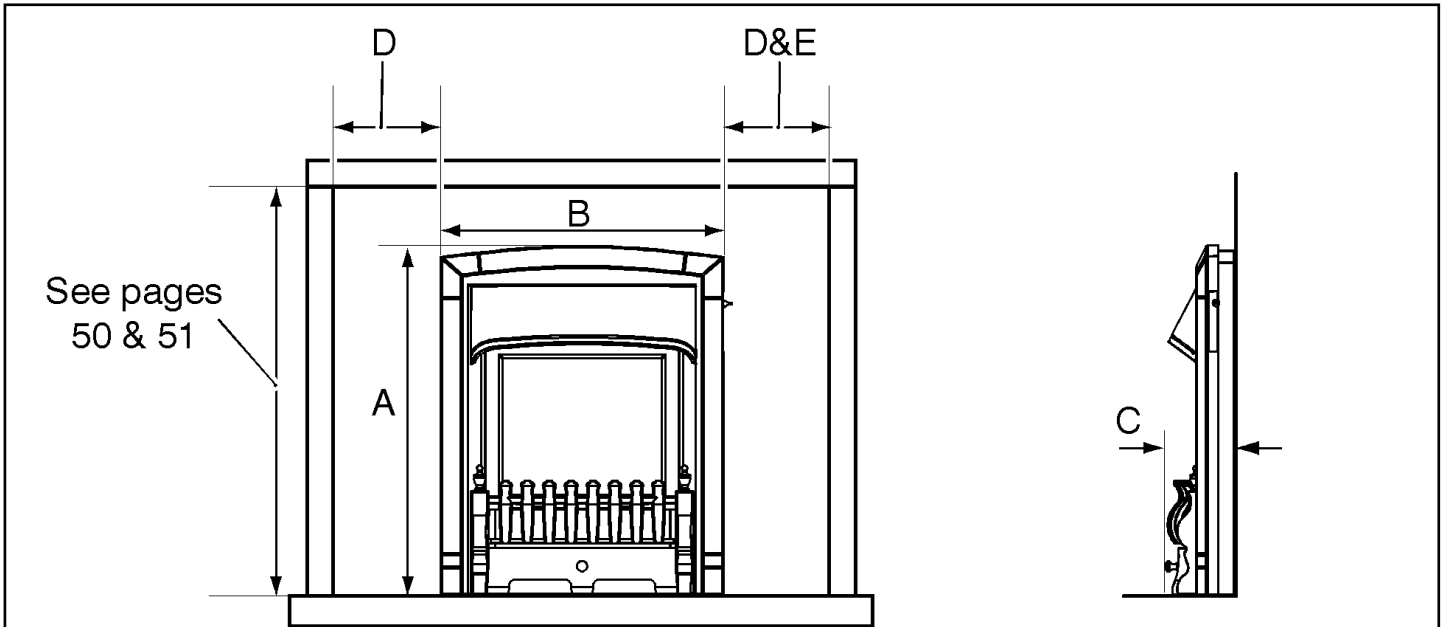

Key	Description	Model	
		Dream/Masq/ Excelsior	Homeflame Petrus
A	Height (mm)	636	636
B	Width (mm)	518	518
C	Depth into room (mm)	142	94
D	Minimum mandatory clearance to combustible surfaces projecting beyond the front of appliance (mm).	100	100
E	Recommended clearance to non-combustible surfaces for access purposes (mm).	50	50

Figure 3. (The fascia may differ from that shown and dimensions are subject to manufacturing tolerances)

OWNER GUIDE

GAS CONSUMPTION

Gross figures

Has a maximum natural gas input of 4.1kW
Has a maximum natural gas output of 3.1kW

Has a minimum natural gas input of 2.3kW
Has a minimum natural gas output of 1.78kW

Net figures

Has a maximum natural gas input of 3.69kW
Has a maximum natural gas output of 3.1kW

Has a minimum natural gas input of 2.07kW
Has a minimum natural gas output of 1.78kW

OPERATING YOUR FIRE

PLEASE NOTE

When operating your fire for the first time, some vapours may be given off which may cause a slight odour and could possibly set off any smoke alarms in the immediate vicinity. These vapours are quite normal with new appliances. They are totally harmless and will disappear after a few hours use.

Valor Fires considers all surfaces as working surfaces (which means they get hot) with the exception of those areas intended to be touched by the owner during normal use.

The Oxysafe flame sensing and flue blockage safety system.

For your safety, this appliance is fitted with a flue blockage safety device which will shut down the appliance in the event of abnormal flue conditions. **This device is NOT a substitute for an independently mounted Carbon Monoxide detector.**

The device will also automatically shut off the gas supply to the fire if the pilot flame goes out due to lack of oxygen or for any other reason.

If this device starts to repeatedly shut off the gas, get expert advice.

This device incorporates a probe which senses that the heat from the pilot flame is correct. If this probe is cool, the device will prevent any gas flow unless the control knob is kept depressed at the ignition position.

If, for any reason, the flames go out when the fire is hot or if the fire is turned off when hot, **always wait at least three minutes before attempting to relight.**

OWNER GUIDE

Lighting the pilot.

The slider knob is located at the upper right hand side of the fire.

The control markings are shown in figure 4.

– Slide the control knob to the bottom (ignition) position marked . In this position, the electronic ignition system should cause a series of sparks that should light the pilot. Within four seconds of the pilot igniting, the main burner should light at its minimum setting.

If no sparks are produced to light the pilot, the battery may need replacing. Details of battery replacement are given in the 'maintenance' section of this manual. Until you can obtain a replacement battery the fire can be lit with a taper as described later in this section.

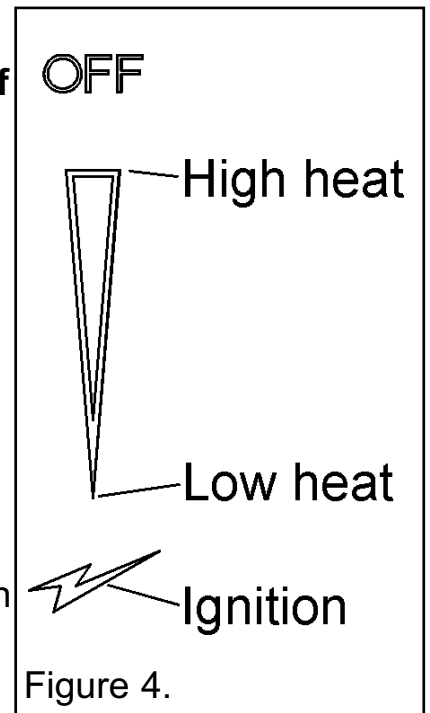

– Keep the knob at the ignition position for a further ten seconds. This will prevent the flame sensing device from shutting off the gas while its probe warms up as explained above.

– If low heat is required, release the knob. The knob will automatically spring up to the low heat position shown in figure 4 (See note i). If for any reason the slider control does not spring up, raise the slider to the 'OFF' position (Topmost position) and contact your installer. Do not use the fire until the problem has been rectified.

– For a higher heat level slide the knob upwards. The burner flames and heat output will gradually increase until the knob reaches the high heat position shown in figure 4. When the knob reaches the high heat position you will feel a check to its movement. Do not slide the knob above the high heat position unless you want to turn the fire off (See note i).

Note

- i. If the flames go out while setting the control, repeat the full lighting procedure. If the flames repeatedly go out have the fire serviced.
- ii. When first turned on the flames will appear predominantly blue. The ceramic fuel effect pieces will take time to warm up. Although some glow will be seen after approximately ten minutes, the full visual effect will only be apparent after a somewhat longer time.
- iii. The appliance will operate to its maximum potential if the flue is primed during the first 20 - 30 minutes of operation. To do this, simply slide the control to its highest setting. This will also burn off any carbon deposits that may have formed during previous operations.
- iv. If operating the appliance for long periods it is beneficial to change between settings. This will also help to remove any carbon deposits that may form during operation.

OWNER GUIDE

Lighting with a taper.

(See figure 5).

- In the unlikely event of failure of the ignition spark, the pilot can be lit by a taper or long spill. With the lower front casting and firefront casting removed, insert the taper or spill under the glass to the pilot tip.
- Follow the section 'Lighting the pilot' as described previously. **DO NOT ALLOW WAX OR OTHER DEPOSITS TO DROP ONTO THE PILOT.**

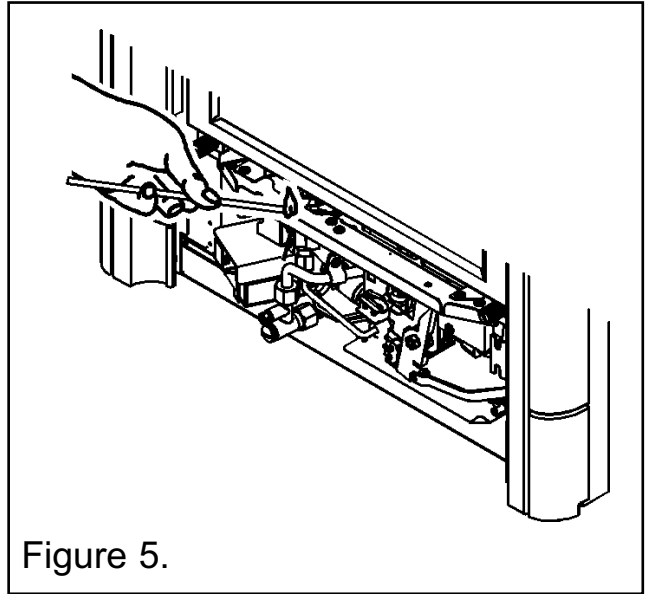

Ignition - Lighting the fire.

When you depress the Fireslide control you should hear a faint ticking sound from the bottom of the fire. This is the sound of the ignition spark that lights the gas. If there is no ticking sound it may be that the battery in the electronic spark generator requires replacement. Details of how to change the battery can be found in the 'MAINTENANCE' section of this guide.

Window - Glass.

Has the window formed white lines or appears milky or grey?

This is normal and is simply caused by the small amounts of condensation / water that form on the rear of the window during the first few minutes of operation. The condensation / water is no cause for concern and will disappear over the first few minutes of the fire being used. The window on the fire has been designed so that you can remove it for cleaning. Details on how to remove and clean the window can be found in the 'CLEANING YOUR FIRE' section of the owner guide.

Fuel effect - Coal bed.

When cleaning the ceramic fuel effect you may see surface cracks in the base coal. It is normal for the base coal to have surface cracks and this will not affect the performance of your fire in any way.

The fuel effect will lighten in colour with use and the areas where flames touch may develop brown edges. This is normal and is no cause for concern.

Does your fire have any signs of the following?

1. The fuel effect has areas that are black in colour (Much darker than the surrounding areas).
2. The fuel effect has areas that are black in colour and the flames are unusually long and dark yellow / orange.
3. Black dust / black particles on the hearth at the base of the fire.

Any of the above can be signs of soot forming in the fire. Please remember that we recommend the fire be serviced annually (Once a year) by a Gas Safe Register engineer (Corgi or Gas Safe Register outside of the UK). If your fire is over 12 months old we strongly recommend that it is serviced.

The rear wall effect.

The rear wall is made from the same material as the fuel effect. As with the fuel effect, the rear wall will lighten in colour with use and the areas where flames touch may develop brown edges. To enhance the appearance of the fire and to produce more glow the flames have been designed to touch the rear wall. Where they touch light areas will form. This is normal and is no cause for concern.

OWNER GUIDE

The reflective sides and top inside the fire.

To improve the appearance of the flames the fire uses reflective surfaces around the fuel effect. These surfaces become very hot and will discolour. The top of the fire above the fuel effect will become quite dark. This is normal and no cause for concern.

CLEANING YOUR FIRE

To maintain the high performance and quality finish of your Valor Fires appliance, please follow these guidelines:

- Before attempting to clean the fire, please remember to turn off the fire and wait for the appliance to cool completely. The fire will retain heat for some time before cleaning can begin.
- If any pieces of debris are found in the firebox, have the chimney inspected before further use.

Metal Parts.

Please be aware that the top and sides that are close to the fuel effect will discolour or darken. This is normal and no need for concern. This discolouration will not clean away.

- Clean the metal parts with a slightly damp, lint free non-abrasive cloth and then dry.
- Do **not** use abrasive cleaners, as these will scratch the fire surface.

Window cleaning and removal.

To clean the front of the window.

The front of the window can be cleaned using a slightly damp, lint free non-abrasive cloth and then dry. Do **not** use abrasive cleaners, as these may scratch the glass surface.

To clean the inside of the window.

- Before the window can be detached, the firefront casting will have to be removed. Remove the lower front cover section of the casting.
- On Dream models, lift the firefront casting clear of the fire. On Petrus models, lift the fire front casting up and forward to release the locating screw heads at the back of the casting from the brackets in the fascia.

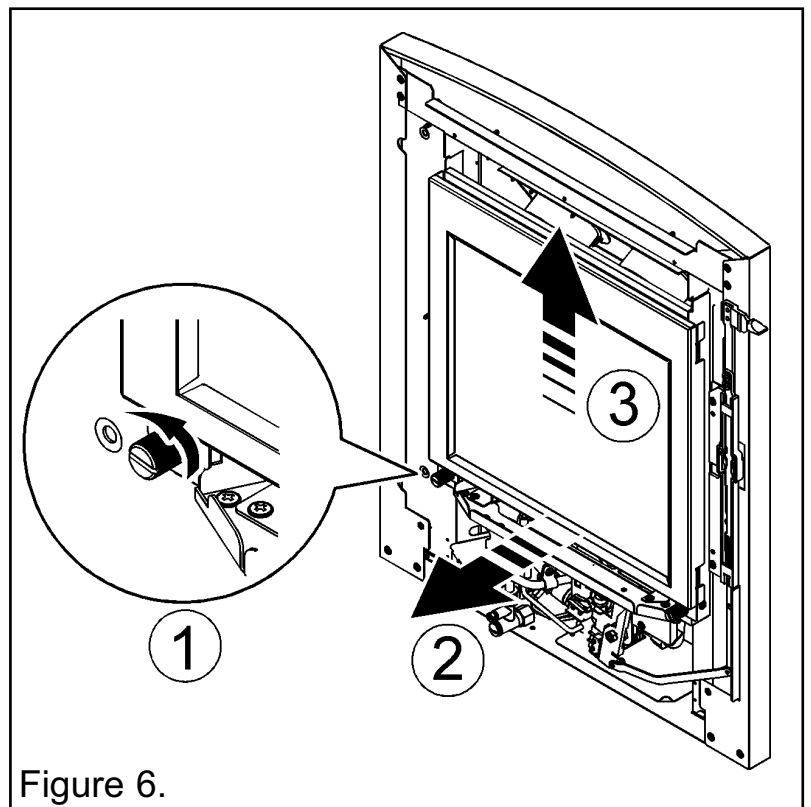

Figure 6.

OWNER GUIDE

- Unscrew and remove the two thumbscrews from the lower corners of the window.
- Gently pull the window forward and upward clear of the fire.
- Any stains on the glass can be removed with a non-abrasive cleaner such as a ceramic hob cleaner. Never use abrasive cleaners. Clean the window carefully in accordance with the instructions supplied with the cleaner.
- Replace the window making sure that the seal around the frame is not damaged or misplaced. Locate the channel at the top of the window over the top of the firebox opening.
- Fit the two thumbscrews. Tighten sufficiently to seal to the firebox.
- Replace the firefront casting and lower front cover casting.

Ceramic fuel effect and rear wall.

- **This product uses fuel effect pieces and a burner compartment wall containing Refractory Ceramic Fibres (RCF), which are man-made vitreous silicate fibres. Excessive exposure to this material may cause irritation to eyes, skin and respiratory tract. Consequently, it is important to take care when handling these articles to ensure that the release of dust is kept to a minimum.**
- Light coatings of soot will usually be burnt off during the normal operation of the fire.
- Should any soot accumulation become excessive, the fuel effect pieces and rear wall should be removed from the fire for cleaning.
- Cleaning should be carried out in a well ventilated area or in the open air by gently brushing with the pieces held away from your face so that you avoid inhaling the dust.
- Remove the window as in the previous section. We suggest that you remove the ceramic fuel effect pieces in the reverse order to that shown in the guide supplied with the ceramics. The installer should have attached this or placed it inside the installer and owner guide.

When cleaning the ceramic fuel effect you may see surface cracks in the base coal. It is normal for the base coal to have surface cracks and this will not affect the performance of your fire in any way.

Burner.

- The burner surface can be carefully cleaned to remove any loose particles after taking off the ceramic fuel effect pieces. Make sure that no particles are pushed into the burner holes.

OWNER GUIDE

CERAMIC FUEL EFFECT REFITTING

The installer and owner guide for the ceramic fuel effect is separate from this guide. The installer may have attached it to this guide or placed it inside. It is important that the installer and owner guide for the ceramic fuel effect is followed correctly. If replacing the ceramic fuel effect, where a new guide is supplied, follow the installer and owner guide supplied with the replacement fuel effect. Keep the replacement installer and owner guide with this owner guide for future reference.

MAINTENANCE

Battery replacement.

The igniter unit uses a 9V **alkaline** battery. It is important that a good quality **alkaline** battery is used to replace it. The use of non-alkaline batteries will result in limited battery life. To replace the battery remove the lower front cover section of the casting. On Dream models, lift the firefront casting clear of the fire. On Petrus models, lift the fire front casting up and forward to release the locating screw heads at the back of the casting from the brackets in the fascia.

1. Remove and discard the battery from the ignition block located below the burner tray at the left side. Please remember to recycle batteries whenever possible.
2. Fit the replacement **alkaline** battery to the ignition block (See figure 7). The +ve and -ve terminal positions are marked on the end of the battery holder body and inside.
3. Replace the firefront casting /front cover casting.

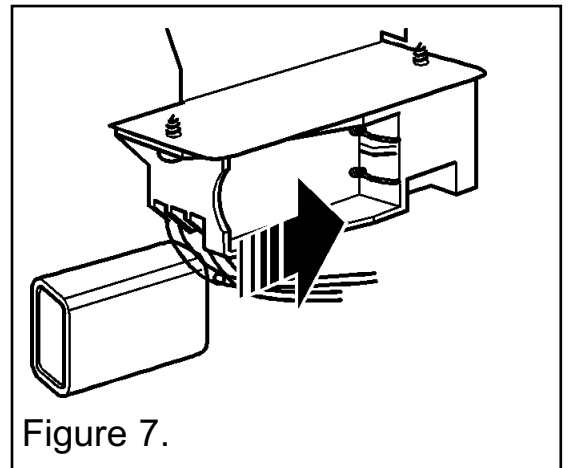

Figure 7.

Regular maintenance.

In order to achieve and maintain high levels of personal safety and performance efficiency, it is essential that the opening at the back of the fire and the flue are kept clear of any form of obstruction. It is possible that deposits of mortar or soot could fall and accumulate causing the flue to be blocked or restricted and so preventing proper clearance of dangerous exhaust fumes.

In the United Kingdom it is the law that a landlord must have any gas appliance, flue and pipework which is situated in a tenant's premises checked for safety at least every twelve months by a competent person (In the UK a GAS SAFE REGISTER engineer, Outside of the UK a CORGI or GAS SAFE REGISTER engineer).

We recommend that all gas appliances and their flues, wherever situated, are checked annually.

– When fitting replacement parts it is important that only approved parts are used for maximum safety.

OWNER GUIDE

Replacement ceramics.

If you wish to replace any of the ceramic fuel effect pieces, spare parts are available via the GDC customer service team.

WARRANTY AND SERVICE

Standard Warranty Terms & Conditions

The warranty is for 12 months subject to contract.

In the United Kingdom servicing can be carried out either by a **GDC** service engineer or a **GAS SAFE REGISTER** engineer. Outside of the United Kingdom servicing can be carried out either by a **CORGI** or **GAS SAFE REGISTER** engineer.

You must register your fire with by calling our telephone registration line on **08444 810 214**.

It is also a requirement of the warranty that the fire has an annual service (every 12 months) in accordance with the installation and servicing instructions, performed by a **GAS SAFE REGISTER** engineer, (**CORGI** or **GAS SAFE REGISTER** outside of UK)



Benchmark Checklist/Service Record

Please ensure that the installer has fully completed the Benchmark Checklist on the inside back pages of the installation instructions supplied with the product and that you have signed it to say that you have received a full and clear explanation of its operation. The installer is legally required to complete a commissioning checklist as a means of complying with the appropriate Building Regulations (England and Wales).

Installations carried out in England and Wales must be notified to Local Area Building Control either directly or through a Competent Persons Scheme. A Building Regulations Compliance Certificate will then be issued to the customer who should, on receipt, write the Notification Number on the Benchmark Checklist.

The filled in Benchmark Checklist/Service Record by the installer will be required in the event of any warranty (UK and Ireland installation).

After servicing, complete the relevant "Service Interval Record" section of the Benchmark Checklist located on the inside back pages of this document.

OWNER GUIDE

Our promise to you

If you experience a fault with your new fire, we aim to provide a safe and high quality repair service supported by our dedicated national network of highly skilled engineers. If your installer can't resolve the problem for you, we will do everything we can to get an engineer out to you as quickly as possible. Nothing in this warranty will affect your statutory rights.

What you need to do if you experience a problem with the operation of the fire:

- You should always contact your installer first, because the cause of the fault may not be related to the fire.
- If your installer confirms that the fault is with the fire and they can't repair it, our friendly customer service team is on hand to help.
- Simply call our UK GDC Helpline on **0844 879 35 88** or from the Republic of Ireland call **01 842 8222** for any general advice that you may need.

When calling the **Helpline**, it would be helpful if you could have the following information to hand:-

1. Fire serial number and fascia code (Located on the information label - See figure 8 on page 64)*.
2. Date of installation*.
3. Your installer name and address details*.
4. Fire make and model number*.
5. Annual Service record details*
6. Proof of purchase (if you do not have the fire serial number)

***Note: details 1 – 5 should be recorded as part of the Benchmark Checklist / Service record at the end of this guide.**

What this warranty covers

Free of charge repair or replacement of components found to be of faulty manufacture.

Free of charge replacement of the complete unit providing the failure is related to a manufacturing fault that cannot be repaired or is uneconomic to repair.

What this warranty does not cover

Repairs to fires which haven't been installed and commissioned properly and as set out in the installation instructions.

Faults caused by inadequate supply of gas or electricity (where applicable).

Reimbursement of any third party repair or replacement costs that we haven't been told about or agreed with you in advance.

Compensation or consequential losses (e.g. loss of earnings, business losses, stress and inconvenience) arising from a production breakdown, including repair delays caused by factors outside our reasonable control.

OWNER GUIDE

GAS FIRE COMMISSIONING CHECKLIST

This Commissioning Checklist is to be completed in full by the competent person who commissioned the gas fire as a means of demonstrating compliance with the appropriate Building Regulations and then handed to the customer to keep for future reference.

Failure to install and commission according to the manufacturer's instructions and complete this Benchmark Commissioning Checklist will invalidate the warranty. This does not affect the customer's statutory rights.

Customer name:		Telephone number:		
Address:				
Gas Fire make and model:				
Gas Fire serial number:				
Commissioned by (PRINT NAME):		Gas Safe register number:		
Company name:		Telephone number:		
Company address:				
		Commissioning date:		
Building Regulations Notification Number (if applicable):				
Site Requirements			Yes	N/A
Was the chimney checked to ensure it only serves one flue/fire, has no obstructions and is continuous?				
Has any debris at the base of the chimney been removed?				
For brick chimney installations is there enough depth for 12 litres of debris, or precast flues 2 litres of debris? (see instructions for debris gap details)				
Have damper and register plates been removed or locked in the fully open position ensuring correct size of flue is maintained?				
If previously used for solid fuel has the chimney been thoroughly swept?				
If the chimney is pre-cast has the inside of the flue been checked for extruded cement / sealant which must be removed?				
Has the fire place been checked for under-floor air supply which must be sealed off?				
Has the chimney been inspected prior to fitting the gas fire to ensure that it is in good condition?				
Has the structure of the chimney been checked for leakage using a smoke pellet test? (See BS5440-1 for details).				
Ventilation				
Does the installation require any additional ventilation requirements as detailed in the manufacturer's instructions?				
Hearth Requirements- where fitted				
Is the hearth constructed from non-combustible material?				
Is the hearth a minimum of 12mm thick with a minimum floor to top surface of 50mm?(BS5871) or as per manufacturer's instructions?				
Is the hearth for open fronted fires a minimum of 760mm wide and has 300mm projecting from the fire opening (BS6871) or to manufacturer's instructions?				
Mounting height (where applicable) has the fire been installed to the correct mounting height- as per manufacturer's instructions?				
Firebox and Fuel Bed				
Has the fuel bed, coals, pebbles etc. been fitted to manufacturer's instructions?				
Gas Supply				
Has an isolation tap/restrictor inlet elbow been fitted for servicing?				
Has the gas supply been thoroughly purged prior to connection to remove any debris?				
Has a gas tightness test been completed prior to breaking into the gas supply and following completion of installation?(IGEM/UP/1B)				
Record burner gas pressure reading? If only the supply pressure is available a gas rate must be undertaken.(GSIUR REG26/9C)				
Record dynamic inlet gas pressure (working pressure) reading (all gas appliances running)				
Spillage test				
Installation passes smoke match test with any extractor fans turned on (see manufacturer's instructions)				
Installation				
Has the gas fire been installed and commissioned in accordance with manufacturer's instructions?				
Has the fire been installed with the correct clearance to combustible materials, as per manufacturer's instructions?				
The operation of the appliance and controls have been demonstrated to the customer including battery replacement where applicable?				
The manufacturer's literature, including Benchmark Checklist and Service record has been explained and left with the customer?				
Has the appliance been registered with the Local Authority as detailed on the Gas Safe web site and is a legal requirement and forms part of the warranty?				
Customer's Signature:		Commissioning Engineer's Signature:		
(To confirm satisfactory demonstration and receipt of manufacturer's literature)				

*All installations in England and Wales must be notified to be Local Authority Building Control (LABC) either directly or through a Persons Scheme. A Building Regulations Compliance Certificate will then be issued to the customer.



OWNER GUIDE

SERVICE RECORD

It is essential that your gas fire is serviced regularly and that the appropriate Service Interval Record is completed.

Service Provider

Before completing the appropriate Service Record below, please ensure you have carried out the service as described in the manufacturer's instructions. Always use the manufacturer's specified spare part when replacing controls.

SERVICE 01	Date:	SERVICE 02	Date:
Engineer name:		Engineer name:	
Company name:		Company name:	
Telephone No:		Telephone No:	
Gas safe register No:		Gas safe register No:	
Comments:		Comments:	
Signature		Signature	
SERVICE 03	Date:	SERVICE 04	Date:
Engineer name:		Engineer name:	
Company name:		Company name:	
Telephone No:		Telephone No:	
Gas safe register No:		Gas safe register No:	
Comments:		Comments:	
Signature		Signature	
SERVICE 05	Date:	SERVICE 06	Date:
Engineer name:		Engineer name:	
Company name:		Company name:	
Telephone No:		Telephone No:	
Gas safe register No:		Gas safe register No:	
Comments:		Comments:	
Signature		Signature	
SERVICE 07	Date:	SERVICE 08	Date:
Engineer name:		Engineer name:	
Company name:		Company name:	
Telephone No:		Telephone No:	
Gas safe register No:		Gas safe register No:	
Comments:		Comments:	
Signature		Signature	
SERVICE 09	Date:	SERVICE 10	Date:
Engineer name:		Engineer name:	
Company name:		Company name:	
Telephone No:		Telephone No:	
Gas safe register No:		Gas safe register No:	
Comments:		Comments:	
Signature		Signature	



OWNER GUIDE

Model

Serial number (Can be found on information label - See figure 8)

SERIAL NUMBER LABEL
TO BE AFFIXED HERE

A LABEL CONTAINING THE SERIAL NUMBER MAY HAVE BEEN PLACED INSIDE THIS BOX.

Fascia name (Block Capitals)

Brand (Please tick)

Valor

Other.....

Date of Installation

D D M M Y Y

Where to find the information label.

